



TLILIC0020 Licence to operate a slewing mobile crane (over 100 Tonnes)

STUDENT ACTIVITY BOOK

Student full name	
Date	

TLILIC0020 Licence to operate a slewing mobile crane (over 100 Tonnes)

This unit specifies the skills and knowledge required to safely operate a slewing mobile crane with a Maximum Rated Capacity (MRC) over 100 tonnes in accordance with all relevant legislative responsibilities. Competence in this unit, does not in itself result in a High-Risk Work Licence (HRWL) to operate this plant.

- Slewing mobile crane means a mobile crane incorporating a boom or jib that can be slewed, but does not include:
- a front-end loader, or
- a backhoe, or
- an excavator, or
- other earth moving equipment, when configured for crane operation.

A person performing this work is required to hold a slewing mobile crane with an MRC over 100 tonnes HRWL.

This unit requires a person operating a slewing mobile crane with an MRC over 100 tonnes to:

- plan for the work/task
- prepare for the work/task
- perform work/task
- pack up.

Licensing/Regulatory Information

Legislative and regulatory requirements are applicable to this unit of competency.

This unit is based on the licensing requirements of Part 4.5 of the Model Work Health and Safety (WHS) regulations and meets Commonwealth, state and territory HRWL requirements.

The National Assessment Instrument (NAI) is the mandated assessment for the HRWL to operate the relevant licensing class as detailed in this unit.

STUDENT ACTIVITY BOOK

STUDENT RECORD OF TRAINING - Student Details

Student full name			
Trainer/Assessor			
Activity book	Satisfactory <input type="checkbox"/>	Not satisfactory <input type="checkbox"/>	
Trainer/Assessor name		Date	
Trainer/Assessor comments			

Student Introduction, Instructions & Guidelines

Application

This unit specifies the skills and knowledge required to safely operate a slewing mobile crane with a Maximum Rated Capacity (MRC) over 100 tonnes in accordance with all relevant legislative responsibilities. Competence in this unit, does not in itself result in a High-Risk Work Licence (HRWL) to operate this plant.

Slewing mobile crane means a mobile crane incorporating a boom or jib that can be slewed, but does not include:

- a front-end loader, or
- a backhoe, or
- an excavator, or
- other earth moving equipment, when configured for crane operation.

A person performing this work is required to hold a slewing mobile crane with an MRC over 100 tonnes HRWL.

This unit requires a person operating a slewing mobile crane with an MRC over 100 tonnes to:

- plan for the work/task
- prepare for the work/task
- perform work/task
- pack up.

Licensing/Regulatory Information

Legislative and regulatory requirements are applicable to this unit of competency.

This unit is based on the licensing requirements of Part 4.5 of the Model Work Health and Safety (WHS) regulations and meets Commonwealth, state and territory HRWL requirements.

The National Assessment Instrument (NAI) is the mandated assessment for the HRWL to operate the relevant licensing class as detailed in this unit.

Welcome to the assessment of TLILIC0020 Licence to operate a slewing mobile crane (over 100 Tonnes) During this assessment, you will work through a Theory Assessment and Practical Assessment with observable tasks. These activities will give you an understanding of this unit.

Elements covered:

1. Plan work/task
2. Prepare for work/task
3. Perform work/task
4. Pack up

Understanding the Assessment

During your training, you will be observed working in various areas of your establishment. You will be assessed on your knowledge, skills and attitude whilst working in these areas. To be successful you must demonstrate competency on an ongoing basis. When you feel confident in a task you have undertaken or are about to undertake, notify your Trainer/Assessor so they can observe you during the task.

You may be assessed in any number of ways:

- You may be asked to explain how to undertake a given task
- You may be observed while carrying out a task
- You may be questioned on your ability to achieve the specified outcome
- You may have to complete various written tasks

Your Trainer/Assessor will carry out these assessments and you will be given notice as to when each assessment will take place.

To complete your assessment for each unit, you must complete all theory and practical assessment pieces to the required standard.

This unit is to be assessed by Theory Assessment and Practical assessment.

- 1. Training and Theory assessment– minimum of 2 days at 8 hrs** *This is an open activity book inclusive of multiple choice and written responses Activity book -short questions, done in class with the Trainer/Assessor. 100% accuracy to be achieved including any verbal responses. Theory assessment - Knowledge test - closed book 100% accuracy to be achieved.*

- 2. Training and Practical Assessment –** by observation- Trainer/Assessor and the Student is given a **minimum of 2 days at 8 hrs** to complete the Practical. *Practical Assessments will include oral questions and observation of the person performing the tasks. Practical Assessments are to be conducted in the work environment wherever possible. Some aspects may be conducted under simulated conditions where issues of safety and environmental damage are limiting factors.*

- 3. Mandated instrument –** Closed book theory and practical observation

STUDENT INSTRUCTIONS

1. This is an open activity book
2. All questions to be attempted
3. Blue/black pen only to be used
4. Discussion with other students is permitted during activity book
5. Assistance from the assessor may be requested to clarify a question
6. All questions must be answered correctly to be successful
7. All errors made by the student to be initialled by the student
8. The assessor may ask verbal questions to clarify points to be successful
9. When you have finished the activity book, complete the coversheet and hand all to your assessor
10. More than one multiple choice answer may be correct

REASONABLE ADJUSTMENT

If you have any special needs that your assessor does not know about, you should let them know as soon as possible before starting any assessment so that your assessor can make changes where possible.

COMPETENT

To be found competent in this unit of competency, you must 'satisfactorily' complete all assessment instruments and be assessed as competent in both the Theory and the Practical assessment.

FEEDBACK

After an assessment, your assessor should give you feedback to let you know how you went and will discuss reassessment opportunities with you if needed. This feedback, along with the assessment result, will be recorded by your assessor on the front page of this assessment.

APPEALS ASSESSMENT

All Students have the right to appeal an assessment if you feel you have not been fairly assessed in either the theory or the practical for this unit. This may include a reassessment or, you can make an appeal by completing our complaints and appeals form. You can find more information about appeals in the student handbook

REASSESSMENT

All Students have the right to be reassessed. You will need to discuss this option with your Trainer/Assessor. Reassessment may include further training, resit the theory assessment or practical assessment.

Guidelines depend on the regulator requirements for example reassessed on the day.

TLILIC0020 Licence to operate a slewing mobile crane (over 100 Tonnes)-ACTIVITY BOOK

Short Questions	S	NS	Short Questions	S	NS
<p>1. How can you identify task requirements?</p> <p>a. Work orders b. Supervisor instructions c. Communications with the site foreman d. All the above</p>	<input type="checkbox"/>	<input type="checkbox"/>	<p>2. What do you need to ensure when planning for lifting operations?</p> <p>a. The lift plan is confirmed with all associated personnel b. A site inspection is conducted according to workplace procedures c. Both a and b</p>	<input type="checkbox"/>	<input type="checkbox"/>
<p>3. What else should be planned for other than hazards prior to starting work? Provide six (6) examples</p> <p>.....</p> <p>.....</p> <p>.....</p> <p>.....</p> <p>.....</p> <p>.....</p> <p>.....</p>	<input type="checkbox"/>	<input type="checkbox"/>	<p>4. What are four (4) ways to access workplace safety information?</p> <p>.....</p> <p>.....</p> <p>.....</p> <p>.....</p>	<input type="checkbox"/>	<input type="checkbox"/>
<p>5. If a high-risk worker is not working safely under a high-risk work licence, what can the work health and safety regulator do? List three examples</p> <p>.....</p> <p>.....</p> <p>.....</p>	<input type="checkbox"/>	<input type="checkbox"/>	<p>6. What must an employer provide, before you can operate a new type of equipment or crane? List four examples</p> <p>.....</p> <p>.....</p> <p>.....</p> <p>.....</p>	<input type="checkbox"/>	<input type="checkbox"/>

TLILIC0020 Licence to operate a slewing mobile crane (over 100 Tonnes)-ACTIVITY BOOK

Short Questions	S	NS	Short Questions	S	NS
<p>7. What obligations do employers have to ensure the health and safety of all workers?</p> <p><i>Provide four (4) examples</i></p> <p>.....</p> <p>.....</p> <p>.....</p> <p>.....</p>	<input type="checkbox"/>	<input type="checkbox"/>	<p>8. List three (3) ways you can ensure you meet the duty of care requirements.</p> <p>.....</p> <p>.....</p> <p>.....</p>	<input type="checkbox"/>	<input type="checkbox"/>

<p>9. Consider the following ground conditions and write the <u>four most suitable</u> in the space provided.</p> <table border="1" style="width: 100%; border-collapse: collapse; margin-top: 10px;"> <thead> <tr> <th style="width: 30%;">Ground conditions</th> <th style="width: 70%;">The most suitable ground conditions to set up a mobile crane are</th> </tr> </thead> <tbody> <tr> <td>Soft / water impacted soil</td> <td></td> </tr> <tr> <td>Rough uneven ground</td> <td>.....</td> </tr> <tr> <td>Shale rock</td> <td>.....</td> </tr> <tr> <td>Sandstone</td> <td>.....</td> </tr> <tr> <td>Compacted gravel with up to 20% sand</td> <td>.....</td> </tr> <tr> <td>Backfilled ground</td> <td>.....</td> </tr> <tr> <td>Hard rock</td> <td></td> </tr> <tr> <td>Bitumen</td> <td></td> </tr> <tr> <td>Hard compacted clay</td> <td></td> </tr> </tbody> </table>	Ground conditions	The most suitable ground conditions to set up a mobile crane are	Soft / water impacted soil		Rough uneven ground	Shale rock	Sandstone	Compacted gravel with up to 20% sand	Backfilled ground	Hard rock		Bitumen		Hard compacted clay		<input type="checkbox"/>	<input type="checkbox"/>
Ground conditions	The most suitable ground conditions to set up a mobile crane are																					
Soft / water impacted soil																						
Rough uneven ground																					
Shale rock																					
Sandstone																					
Compacted gravel with up to 20% sand																					
Backfilled ground																					
Hard rock																						
Bitumen																						
Hard compacted clay																						

TLILIC0020 Licence to operate a slewing mobile crane (over 100 Tonnes)-ACTIVITY BOOK

Short Questions	S	NS	Short Questions	S	NS
<p>10. How can you assess ground conditions including the bearing pressure value of soil?</p> <p>.....</p> <p>.....</p>	<input type="checkbox"/>	<input type="checkbox"/>	<p>11. Why do you need to consider, the ground bearing capacity, for the type of ground you intend to set up on?</p> <p>.....</p> <p>.....</p> <p>.....</p> <p>.....</p> <p>.....</p>	<input type="checkbox"/>	<input type="checkbox"/>
<p>12. Complete the following questions</p> <div style="border: 1px solid black; padding: 5px; margin: 5px 0;"> <p>What information must be established before setting up a mobile crane on a concrete floor?</p> <p>.....</p> </div> <div style="border: 1px solid black; padding: 5px; margin: 5px 0;"> <p>How can you establish this information?</p> <p>.....</p> </div>				<input type="checkbox"/>	<input type="checkbox"/>
<p>13. Complete the following questions</p> <div style="border: 1px solid black; padding: 5px; margin: 5px 0;"> <p>Why is it dangerous to set up any part of a crane including the wheels or outriggers near a trench or recently excavated ground?</p> <p>.....</p> </div> <div style="border: 1px solid black; padding: 5px; margin: 5px 0;"> <p>What distance from a trench excavation can you set up a crane?</p> <p>.....</p> </div>				<input type="checkbox"/>	<input type="checkbox"/>

TLILIC0020 Licence to operate a slewing mobile crane (over 100 Tonnes)-ACTIVITY BOOK

Short Questions	S	NS	Short Questions	S	NS
<p>14. What would you refer to in order to find out the crane's lifting/rated capacity?</p> <p>.....</p> <p>.....</p> <p>.....</p> <p>.....</p>	<input type="checkbox"/>	<input type="checkbox"/>	<p>15. How would you identify the Working Load Limit (WLL) of the crane hook?</p> <p>.....</p> <p>.....</p> <p>.....</p> <p>.....</p>	<input type="checkbox"/>	<input type="checkbox"/>
<p>16. What activities will require detailed and documented lifting procedures?</p> <p><i>Provide four examples</i></p> <p>.....</p> <p>.....</p> <p>.....</p> <p>.....</p>	<input type="checkbox"/>	<input type="checkbox"/>	<p>17. Why is it necessary that load charts, signs or labels are in place and can be read easily?</p> <p>.....</p> <p>.....</p> <p>.....</p> <p>.....</p>	<input type="checkbox"/>	<input type="checkbox"/>
<p>18. List three (3) types of information found in a load chart.</p> <p>.....</p> <p>.....</p> <p>.....</p>	<input type="checkbox"/>	<input type="checkbox"/>			

TLILIC0020 Licence to operate a slewing mobile crane (over 100 Tonnes)-ACTIVITY BOOK

Short Questions	S	NS	Short Questions	S	NS
-----------------	---	----	-----------------	---	----

19. Consider the crane configuration below.
 Which outrigger has the most load if the crane has no load on the boom although is fitted with a counterweight?
 Explain your answer

<input type="checkbox"/>	<input type="checkbox"/>
--------------------------	--------------------------

.....

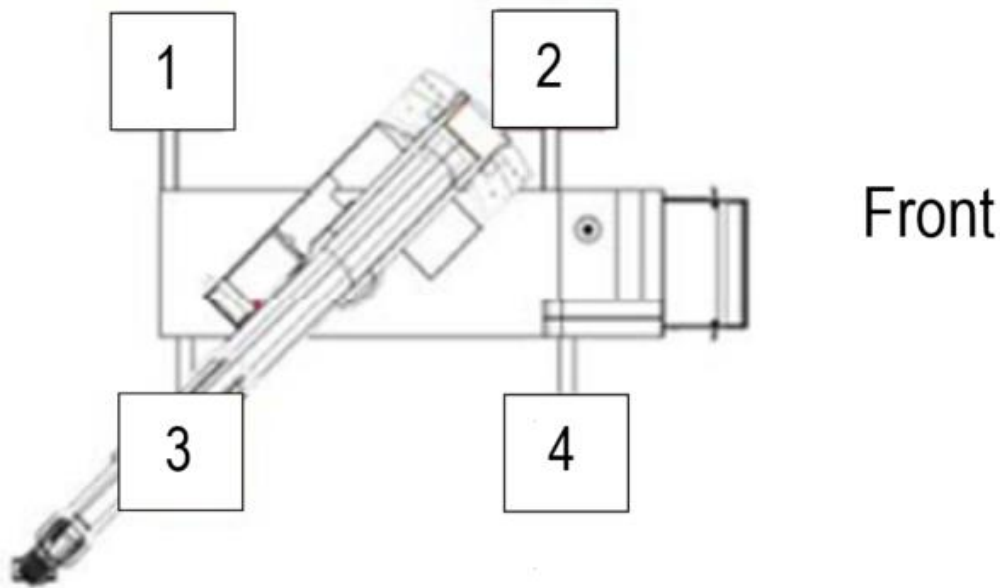

20. What do you need to plan for when working out the appropriate path of movement for a crane and load?

Provide five examples

.....

.....

.....

.....

.....

<input type="checkbox"/>	<input type="checkbox"/>
--------------------------	--------------------------

21. How would you assess and determine appropriate paths for operating and moving loads?

- a. Inspected and determined at the planning stage
- b. By consulting with other personnel involved in the lift or working in the immediate area
- c. By following workplace procedures
- d. All the above

<input type="checkbox"/>	<input type="checkbox"/>
--------------------------	--------------------------

TLILIC0020 Licence to operate a slewing mobile crane (over 100 Tonnes)-ACTIVITY BOOK

Short Questions	S	NS	Short Questions	S	NS
<p>22. Why wouldn't you lift or lower a load over people?</p> <p>.....</p> <p>.....</p> <p>.....</p>	<input type="checkbox"/>	<input type="checkbox"/>			
<p>23. Briefly explain the meaning of the following terms</p> <div style="border: 1px solid black; padding: 5px; margin-bottom: 5px;"> <p>A Hazard</p> <p>.....</p> </div> <div style="border: 1px solid black; padding: 5px;"> <p>A Risk</p> <p>.....</p> </div>				<input type="checkbox"/>	<input type="checkbox"/>
<p>24. Complete the following questions</p> <div style="border: 1px solid black; padding: 5px; margin-bottom: 5px;"> <p>What is the risk when a person is near a crane boom that is being retracted or extended, how can you control this risk?</p> <p>Risk</p> <p>.....</p> <p>Control</p> <p>.....</p> </div> <div style="border: 1px solid black; padding: 5px;"> <p>What is the risk for a person near the structure of a crane during operations, how can this be controlled?</p> <p>Risk</p> <p>.....</p> <p>Control</p> <p>.....</p> </div>				<input type="checkbox"/>	<input type="checkbox"/>

TLILIC0020 Licence to operate a slewing mobile crane (over 100 Tonnes)-ACTIVITY BOOK

Short Questions	S	NS	Short Questions	S	NS
<p>25. List seven (7) potential hazards which could affect crane operations.</p> <p>.....</p> <p>.....</p> <p>.....</p> <p>.....</p> <p>.....</p> <p>.....</p> <p>.....</p>	<input type="checkbox"/>	<input type="checkbox"/>	<p>26. Number 1-6, the following hierarchy of hazard control in the correct order of effectiveness, 1 being most effective.</p> <p><input type="checkbox"/> Engineering controls</p> <p><input type="checkbox"/> Personal Protective Equipment</p> <p><input type="checkbox"/> Elimination</p> <p><input type="checkbox"/> Isolation</p> <p><input type="checkbox"/> Administrative controls</p> <p><input type="checkbox"/> Substitution</p>	<input type="checkbox"/>	<input type="checkbox"/>
<p>27. Complete the following questions.</p> <div style="border: 1px solid black; padding: 10px; margin: 10px 0;"> <p>List four (4) persons you could speak with about workplace hazards before working.</p> <p>.....</p> <p>.....</p> <p>.....</p> <p>.....</p> </div> <div style="border: 1px solid black; padding: 10px; margin: 10px 0;"> <p>Why would you speak to other persons about workplace hazards before working?</p> <p>.....</p> <p>.....</p> </div>				<input type="checkbox"/>	<input type="checkbox"/>

TLILIC0020 Licence to operate a slewing mobile crane (over 100 Tonnes)-ACTIVITY BOOK

Short Questions	S	NS	Short Questions	S	NS
<p>28. List three (3) visual signs to identify the location of power lines on your worksite.</p> <p>.....</p> <p>.....</p> <p>.....</p>	<input type="checkbox"/>	<input type="checkbox"/>	<p>29. What controls can you put in place for the safety of other workers in the area?</p> <p>.....</p> <p>.....</p> <p>.....</p>	<input type="checkbox"/>	<input type="checkbox"/>
<p>30. What needs to be in place before operating a crane at night?</p> <p>.....</p> <p>.....</p> <p>.....</p>	<input type="checkbox"/>	<input type="checkbox"/>	<p>31. Who would you refer to for the correct voltage of overhead electric lines?</p> <p>.....</p> <p>.....</p> <p>.....</p>	<input type="checkbox"/>	<input type="checkbox"/>
<p>32. If necessary, how can you work closer than the prescribed safe operating distance for power lines?</p> <p><i>Provide three examples</i></p> <p>.....</p> <p>.....</p> <p>.....</p>	<input type="checkbox"/>	<input type="checkbox"/>			

TLILIC0020 Licence to operate a slewing mobile crane (over 100 Tonnes)-ACTIVITY BOOK

Short Questions	S	NS	Short Questions	S	NS																		
<p>33. What minimum safe distances must you maintain when working near electric lines <u>in your state</u>?</p> <table border="1" style="margin-left: 20px;"> <tr> <td colspan="2">QLD</td> </tr> <tr> <td>Up to 132,000 volts</td> <td></td> </tr> <tr> <td>Between 132,000 and 330,000 volts</td> <td></td> </tr> <tr> <td>Above 330,000 volts</td> <td></td> </tr> </table> <table border="1" style="margin-left: 20px;"> <tr> <td colspan="2">NT</td> </tr> <tr> <td>50v to 1000v</td> <td></td> </tr> <tr> <td>1000v to 33000v</td> <td></td> </tr> <tr> <td>33000v to 66000v</td> <td></td> </tr> <tr> <td>66000v to 132000v</td> <td></td> </tr> </table>	QLD		Up to 132,000 volts		Between 132,000 and 330,000 volts		Above 330,000 volts		NT		50v to 1000v		1000v to 33000v		33000v to 66000v		66000v to 132000v					<input type="checkbox"/>	<input type="checkbox"/>
QLD																							
Up to 132,000 volts																							
Between 132,000 and 330,000 volts																							
Above 330,000 volts																							
NT																							
50v to 1000v																							
1000v to 33000v																							
33000v to 66000v																							
66000v to 132000v																							
<p>34. What are six (6) actions you would take if your crane touches overhead electric lines?</p> <p>.....</p> <p>.....</p> <p>.....</p> <p>.....</p> <p>.....</p> <p>.....</p>	<input type="checkbox"/>	<input type="checkbox"/>	<p>35. What plan will provide guidance on signage and isolation requirements for pedestrians or vehicles?</p> <p>a. The traffic control plan</p> <p>b. Safety data sheets</p> <p>c. Environmental management plan</p> <p>d. None of the above</p>	<input type="checkbox"/>	<input type="checkbox"/>																		

TLILIC0020 Licence to operate a slewing mobile crane (over 100 Tonnes)-ACTIVITY BOOK

Short Questions	S	NS	Short Questions	S	NS
<p>36. What are three (3) checks you would make with the local authority before setting up a mobile crane in an active street?</p> <p>.....</p> <p>.....</p> <p>.....</p>	<input type="checkbox"/>	<input type="checkbox"/>	<p>37. When would you decide the best communication methods for the task and who would you establish this with?</p> <p>.....</p> <p>.....</p> <p>.....</p>	<input type="checkbox"/>	<input type="checkbox"/>
<p>38. When would you check two-way radio or communication equipment?</p> <p>.....</p> <p>.....</p> <p>.....</p>	<input type="checkbox"/>	<input type="checkbox"/>	<p>39. When using a crane workbox with a worker where should the person dogging the load be positioned?</p> <p>.....</p> <p>.....</p> <p>.....</p>	<input type="checkbox"/>	<input type="checkbox"/>
<p>40. At what height are fall prevention and fall arrest equipment required?</p> <p>a. 2m or higher</p> <p>b. 5 m</p> <p>c. 3m and above</p> <p>d. 4m</p>	<input type="checkbox"/>	<input type="checkbox"/>	<p>41. How can you ensure requirements or procedures for a specific work area are met?</p> <p>a. Confirm task requirements</p> <p>b. Work in accordance with the lift plan and workplace procedures</p> <p>c. Follow Safe work method statements</p> <p>d. All the above</p>	<input type="checkbox"/>	<input type="checkbox"/>
<p>42. What types of information will supply details on the safe use and care of slings?</p> <p>.....</p> <p>.....</p> <p>.....</p>	<input type="checkbox"/>	<input type="checkbox"/>			

TLILIC0020 Licence to operate a slewing mobile crane (over 100 Tonnes)-ACTIVITY BOOK

Short Questions	S	NS	Short Questions	S	NS		
<p>43. Complete the following questions</p> <div style="border: 1px solid black; padding: 10px; margin: 10px 0;"> <p>What are three (3) methods a dogger or rigger can use to direct the crane?</p> <p>.....</p> <p>.....</p> <p>.....</p> </div> <div style="border: 1px solid black; padding: 10px; margin: 10px 0;"> <p>When would each method be used?</p> <p>.....</p> <p>.....</p> <p>.....</p> <p>.....</p> <p>.....</p> </div>						<input type="checkbox"/>	<input type="checkbox"/>
<p>44. Why would you establish and maintain communications with workplace personnel?</p> <p>a. To ensure the lift plan is understood clearly</p> <p>b. To ensure the lift plan meets the site requirements and workplace procedures</p> <p>c. Both a and b</p>	<input type="checkbox"/>	<input type="checkbox"/>	<p>45. When would you check your risk controls for identified hazards?</p> <p>.....</p> <p>.....</p>	<input type="checkbox"/>	<input type="checkbox"/>		

TLILIC0020 Licence to operate a slewing mobile crane (over 100 Tonnes)-ACTIVITY BOOK

Short Questions	S	NS	Short Questions	S	NS
<p>46. When can an out of service, danger or safety tag be removed?</p> <p>.....</p> <p>.....</p> <p>.....</p> <p>.....</p>	<input type="checkbox"/>	<input type="checkbox"/>	<p>47. How would you access a crane safely?</p> <p>a. 1 point (your supervisor)</p> <p>b. Use 3 points of contact (two hands one foot or two feet one hand)</p> <p>c. According to manufacturer requirements and safe work procedures</p> <p>d. None of the above</p>	<input type="checkbox"/>	<input type="checkbox"/>
<p>48. List eight (8) pre-start checks before operating a slewing mobile crane.</p> <p>.....</p> <p>.....</p> <p>.....</p> <p>.....</p> <p>.....</p> <p>.....</p> <p>.....</p>	<input type="checkbox"/>	<input type="checkbox"/>	<p>49. How would you test a load moment indicator for accuracy?</p> <p>.....</p> <p>.....</p>	<input type="checkbox"/>	<input type="checkbox"/>
<p>50. Why should tyre pressure and condition be checked before operating a crane on tyres where a manufacturer permits?</p> <p>.....</p> <p>.....</p> <p>.....</p>	<input type="checkbox"/>	<input type="checkbox"/>	<p>51. How can you establish how much wire rope should sit in the base of the sheave groove?</p> <p>.....</p> <p>.....</p>	<input type="checkbox"/>	<input type="checkbox"/>

TLILIC0020 Licence to operate a slewing mobile crane (over 100 Tonnes)-ACTIVITY BOOK

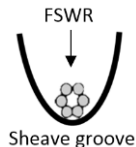
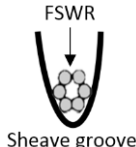
Short Questions	S	NS	Short Questions	S	NS
<p>52. How can you establish the correct depth of the sheave-groove in regards to the diameter of the wire rope being used?</p> <p>.....</p> <p>.....</p>	<input type="checkbox"/>	<input type="checkbox"/>	<p>53. How many full turns of wire must remain on the winch drum when the hook or block is as low as possible?</p> <p>.....</p> <p>.....</p> <p>.....</p>	<input type="checkbox"/>	<input type="checkbox"/>
<p>54. Complete the following questions</p> <div style="border: 1px solid black; padding: 5px;"> <p>What is the risk when a sheave groove is too large for the wire rope diameter?</p>  <p>Sheave groove</p> <p>.....</p> <p>.....</p> </div> <div style="border: 1px solid black; padding: 5px; margin-top: 5px;"> <p>What is the risk when a sheave groove is too small for the wire rope diameter?</p>  <p>Sheave groove</p> <p>.....</p> <p>.....</p> </div>				<input type="checkbox"/>	<input type="checkbox"/>
<p>55. List four (4) visual clues that may indicate a crane boom or superstructure defect.</p> <p>.....</p> <p>.....</p> <p>.....</p> <p>.....</p>	<input type="checkbox"/>	<input type="checkbox"/>	<p>56. What defects make a sheave unsafe to use?</p> <p><i>Provide five examples</i></p> <p>.....</p> <p>.....</p> <p>.....</p> <p>.....</p> <p>.....</p>	<input type="checkbox"/>	<input type="checkbox"/>

TLILIC0020 Licence to operate a slewing mobile crane (over 100 Tonnes)-ACTIVITY BOOK

Short Questions	S	NS	Short Questions	S	NS
<p>57. What is the procedure if any damage or defect is identified during a pre-start check?</p> <p>.....</p> <p>.....</p> <p>.....</p> <p>.....</p> <p>.....</p>	<input type="checkbox"/>	<input type="checkbox"/>	<p>58. What amount of wear and tear on lifting equipment including shackles deems it not safe to use?</p> <p>.....</p>	<input type="checkbox"/>	<input type="checkbox"/>
<p>59. Complete the following questions</p> <div style="border: 1px solid black; padding: 10px; margin: 10px 0;"> <p>What is fitted to the tail projection of the dead-end of a rope used with a wedge socket?</p> <p>.....</p> <p>.....</p> <p>.....</p> </div> <div style="border: 1px solid black; padding: 10px; margin: 10px 0;"> <p>Why is this method be used?</p> <p>.....</p> </div> <div style="border: 1px solid black; padding: 10px; margin: 10px 0;"> <p>List two (2) methods to fasten the tail of the hoist rope to the winch drum.</p> <p>.....</p> <p>.....</p> </div>				<input type="checkbox"/>	<input type="checkbox"/>

TLILIC0020 Licence to operate a slewing mobile crane (over 100 Tonnes)-ACTIVITY BOOK

Short Questions	S	NS	Short Questions	S	NS
<p>60. List three (3) preparations when checking the slewing mobile crane for on-road travel.</p> <p>.....</p> <p>.....</p> <p>.....</p>	<input type="checkbox"/>	<input type="checkbox"/>	<p>61. What is the purpose of checking a crane and related equipment before use?</p> <p>.....</p> <p>.....</p>	<input type="checkbox"/>	<input type="checkbox"/>
<p>62. Complete the following questions</p> <div style="border: 1px solid black; padding: 10px; margin: 10px 0;"> <p>What has happened if the boom pawl has engaged the ratchet?</p> <p>.....</p> </div> <div style="border: 1px solid black; padding: 10px; margin: 10px 0;"> <p>When the luff pawl is engaged why should you luff down carefully?</p> <p>.....</p> </div> <div style="border: 1px solid black; padding: 10px; margin: 10px 0;"> <p>How would the track pressure change when a crawler crane has a load on the hook with the jib luffing down?</p> <p>.....</p> <p>.....</p> </div>				<input type="checkbox"/>	<input type="checkbox"/>

TLILIC0020 Licence to operate a slewing mobile crane (over 100 Tonnes)-ACTIVITY BOOK

Short Questions	S	NS	Short Questions	S	NS
<p>63. What checks should be done after positioning a crane and before levelling and packing?</p> <p>.....</p> <p>.....</p> <p>.....</p> <p>.....</p> <p>.....</p> <p>.....</p>	<input type="checkbox"/>	<input type="checkbox"/>	<p>64. How can you establish the most stable side to lift over where a manufacturer permits a crane to operate on rubber tyres?</p> <p>.....</p> <p>.....</p>	<input type="checkbox"/>	<input type="checkbox"/>
<p>65. What tool can you use to ensure the crane is set up level?</p> <p>.....</p> <p>.....</p>	<input type="checkbox"/>	<input type="checkbox"/>	<p>66. When pigstyng with hardwood packing, what angle is the second layer placed at?</p> <p>.....</p> <p>.....</p>	<input type="checkbox"/>	<input type="checkbox"/>
<p>67. Why do you need to work out the minimum area of packing needed under each outrigger?</p> <p>.....</p> <p>.....</p>	<input type="checkbox"/>	<input type="checkbox"/>	<p>68. When can a mobile crane be operated with partly extended outriggers?</p> <p>.....</p> <p>.....</p>	<input type="checkbox"/>	<input type="checkbox"/>

TLILIC0020 Licence to operate a slewing mobile crane (over 100 Tonnes)-ACTIVITY BOOK

Short Questions	S	NS	Short Questions	S	NS
<p>69. What would you do if one or more of the outriggers start to sink? <i>Provide two (2) examples</i></p> <p>.....</p> <p>.....</p> <p>.....</p> <p>.....</p>	<input type="checkbox"/>	<input type="checkbox"/>	<p>70. What elements must be considered to ensure stability throughout crane operations? <i>Provide three examples</i></p> <p>.....</p> <p>.....</p> <p>.....</p>	<input type="checkbox"/>	<input type="checkbox"/>
<p>71. What can happen if outriggers are not fully extended?</p> <p>.....</p> <p>.....</p>	<input type="checkbox"/>	<input type="checkbox"/>	<p>72. What would you refer to when setting up and securing counterweights?</p> <p>.....</p> <p>.....</p>	<input type="checkbox"/>	<input type="checkbox"/>
<p>73. How can you establish if a crane can be travelled with a load on the fly jib?</p> <p>.....</p> <p>.....</p>	<input type="checkbox"/>	<input type="checkbox"/>	<p>74. If you offset the fly jib at 15 degrees, would it have a lower or higher rated load capacity than at 0 degrees?</p> <p>.....</p>	<input type="checkbox"/>	<input type="checkbox"/>

TLILIC0020 Licence to operate a slewing mobile crane (over 100 Tonnes)-ACTIVITY BOOK

Short Questions	S	NS	Short Questions	S	NS
-----------------	---	----	-----------------	---	----

75. Complete the following questions

What operational checks must be performed after start-up?

Provide six examples

.....

.....

.....

.....

.....

.....

What under body checks would you conduct before operating a crawler crane?

Provide four examples

.....







.....

.....

.....

TLILIC0020 Licence to operate a slewing mobile crane (over 100 Tonnes)-ACTIVITY BOOK

Short Questions	S	NS	Short Questions	S	NS
<p>76. Who would you report to if you find any faults or indications that someone has interfered with the crane?</p> <p>.....</p> <p>.....</p> <p>.....</p>	<input type="checkbox"/>	<input type="checkbox"/>	<p>77. Why would you check the crane functions and test to the full extent of operation before commencing work?</p> <p>.....</p> <p>.....</p> <p>.....</p>	<input type="checkbox"/>	<input type="checkbox"/>
<p>78. What action would you take in the event a limiting device is found faulty?</p> <p>.....</p> <p>.....</p> <p>.....</p> <p>.....</p> <p>.....</p>	<input type="checkbox"/>	<input type="checkbox"/>	<p>79. What checks of a crane log book would you make?</p> <p><i>Provide three examples</i></p> <p>.....</p> <p>.....</p> <p>.....</p>	<input type="checkbox"/>	<input type="checkbox"/>
<p>80. Using the weather forecast provided below, which days will be potentially hazardous to operate a crane rated to a safe wind speed of 39km/h.</p> <p>.....</p>				<input type="checkbox"/>	<input type="checkbox"/>

Monday	Tuesday	Wednesday	Thursday	Friday	Saturday
					
17°/13°	17°/13°	18°/12°	18°/12°	20°/8°	15°/8°
Wind South at 42km/h	Wind North at 15km/h	Wind North at 15km/h	Wind North at 25km/h	Wind North at 30km/h	Wind South at 41km/h

TLILIC0020 Licence to operate a slewing mobile crane (over 100 Tonnes)-ACTIVITY BOOK

Short Questions	S	NS	Short Questions	S	NS
<p>81. How can you control the risk associated with high UV exposure?</p> <p>a. Wear appropriate sun protection & clothing including a hat</p> <p>b. Drink plenty of water</p> <p>c. Take breaks</p> <p>d. Plan to work in lower UV rated times or days if possible</p> <p>e. All the above</p>	<input type="checkbox"/>	<input type="checkbox"/>	<p>82. What are the risks of operating a crane in windy conditions?</p> <p><i>Provide (3) examples to the load and crane</i></p> <p>.....</p> <p>.....</p> <p>.....</p>	<input type="checkbox"/>	<input type="checkbox"/>
<p>83. Where would you locate the maximum wind velocity for the slewing mobile crane?</p> <p><i>Provide two examples</i></p> <p>.....</p> <p>.....</p> <p>.....</p> <p>.....</p>	<input type="checkbox"/>	<input type="checkbox"/>	<p>84. What is the risk of positioning the boom/jib into the wind?</p> <p>.....</p> <p>.....</p> <p>.....</p>	<input type="checkbox"/>	<input type="checkbox"/>
<p>85. What is a wind load when operating a mobile crane?</p> <p>.....</p> <p>.....</p> <p>.....</p>	<input type="checkbox"/>	<input type="checkbox"/>	<p>86. What is a dynamic force when operating a slewing mobile crane?</p> <p>.....</p> <p>.....</p> <p>.....</p>	<input type="checkbox"/>	<input type="checkbox"/>

TLILIC0020 Licence to operate a slewing mobile crane (over 100 Tonnes)-ACTIVITY BOOK

Short Questions	S	NS	Short Questions	S	NS
<p>87. List five (5) considerations when setting up a crane in a restricted space.</p> <p>.....</p> <p>.....</p> <p>.....</p> <p>.....</p> <p>.....</p>	<input type="checkbox"/>	<input type="checkbox"/>	<p>88. List three (3) considerations when setting up a crane close to buildings.</p> <p>.....</p> <p>.....</p> <p>.....</p>	<input type="checkbox"/>	<input type="checkbox"/>
<p>89. What would you do in the event that an outrigger pad sinks during a crane task?</p> <p><i>Provide three (3) examples</i></p> <p>.....</p> <p>.....</p> <p>.....</p> <p>.....</p> <p>.....</p> <p>.....</p> <p>.....</p>	<input type="checkbox"/>	<input type="checkbox"/>	<p>90. What action would you take if the load is affected by wind and deemed unsafe?</p> <p>.....</p> <p>.....</p> <p>.....</p>	<input type="checkbox"/>	<input type="checkbox"/>

TLILIC0020 Licence to operate a slewing mobile crane (over 100 Tonnes)-ACTIVITY BOOK

Short Questions	S	NS	Short Questions	S	NS
-----------------	---	----	-----------------	---	----

91. Determine the approximate weight of the following loads.

200 litres of water

.....

1 cubic metre of steel

.....

1 cubic metre of concrete

.....

Load Material	Approximate Weight per m ³	Load Material	Approximate Weight per m ³
Aluminium	2700kg / m ³	Granite	2600kg / m ³
Bricks	4000kg / 1000	Gypsum	2300kg / m ³
Bronze	8500kg / m ³	Iron, ore	5400kg / m ³
Cast Iron	7200kg / m ³	Lead	11200kg / m ³
Cement (25 bags)	1000kg	Steel	7850kg / m ³
Clay	1900kg / m ³	Poly Pipe	1100kg / m ³
Coal	864kg / m ³	Timber (hardwood)	1100kg / m ³
Concrete	2400kg / m ³	Timber (soft)	600kg / m ³
Copper	9000kg / m ³	Water	1000kg / m ³ 1L = 1kg
Earth	1900kg / m ³		

92. What methods can be used to assess or confirm load weight?

Provide four examples

.....

TLILIC0020 Licence to operate a slewing mobile crane (over 100 Tonnes)-ACTIVITY BOOK

Short Questions	S	NS	Short Questions	S	NS
-----------------	---	----	-----------------	---	----

93. Calculate load factors due to the included sling angle in the below configurations



What is the load factor for an included sling angle of 90°?

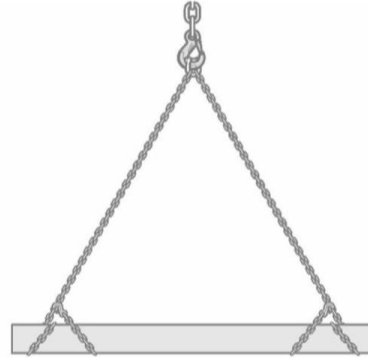

What is the load factor for an included sling angle of 60°?

Note: remember to account for choke factor

94. What information would be displayed on a synthetic sling tag?

Provide four examples

-
-
-
-

95. What information will help you to calculate the derated (reduced capacity) of lifting equipment?

- a. Slinging techniques
- b. Sling tags
- c. Angle factor
- d. All the above

TLILIC0020 Licence to operate a slewing mobile crane (over 100 Tonnes)-ACTIVITY BOOK

Short Questions	S	NS	Short Questions	S	NS
-----------------	---	----	-----------------	---	----



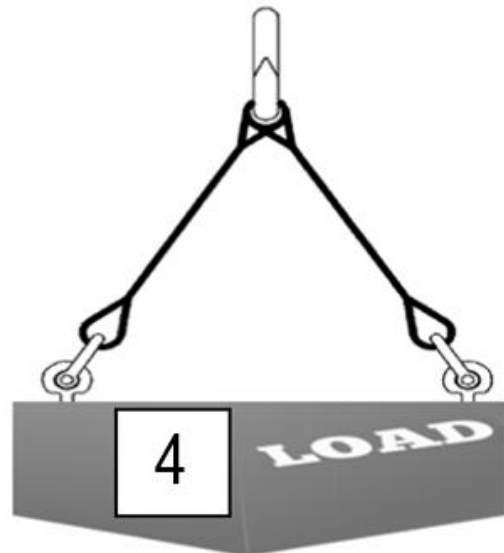
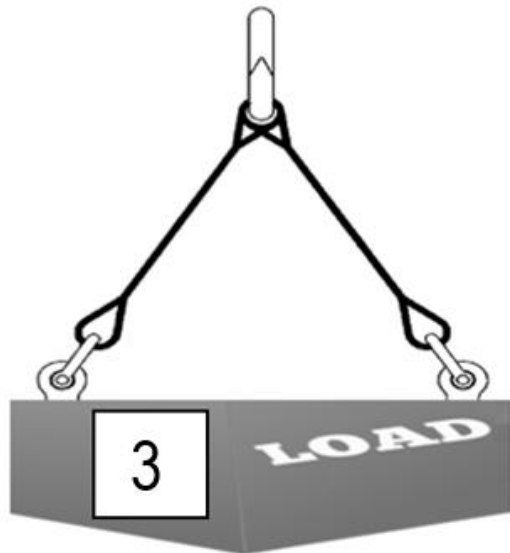
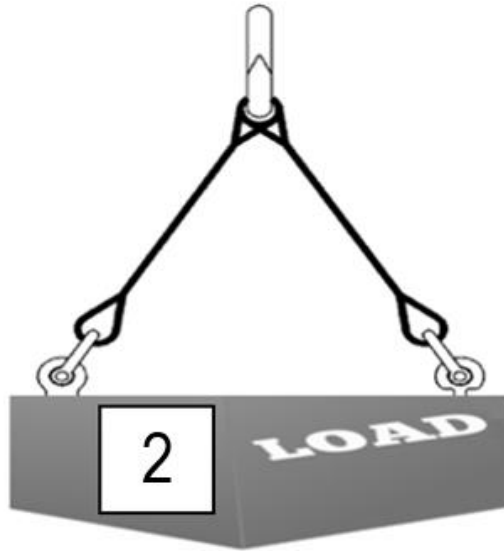
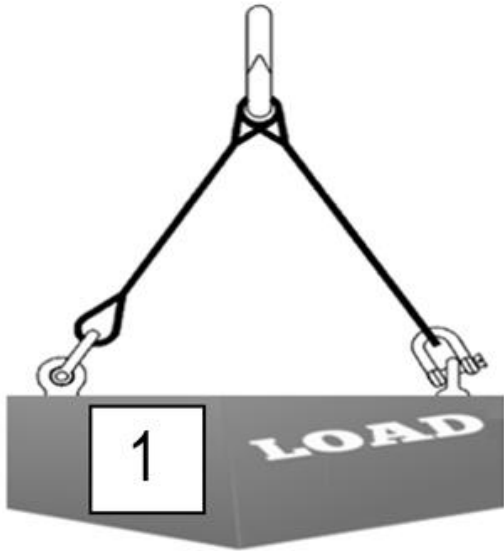

96. Which is the correct method of use when using eyebolts with a two-legged sling?

Circle your answer.

Note: Diagram contains collared and un-collared eyebolts.

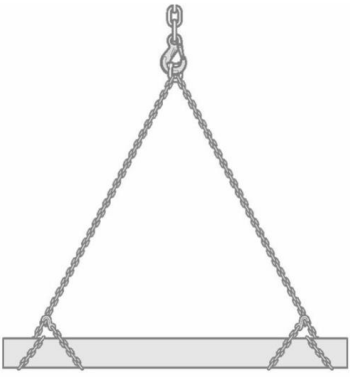

TLILIC0020 Licence to operate a slewing mobile crane (over 100 Tonnes)-ACTIVITY BOOK

Short Questions	S	NS	Short Questions	S	NS
<p>100. What type of shackle would you use to lift a load with multiple slings?</p> <p>.....</p> <p>.....</p>	<input type="checkbox"/>	<input type="checkbox"/>	<p>101. What is the meaning of the letters stamped on the following chain slings?</p> <p>T =</p> <p>V =</p>	<input type="checkbox"/>	<input type="checkbox"/>
<p>102. How can you ensure the reeves will not slip when choking a chain sling around a steel beam at an angle of 60°?</p> <p>.....</p> 	<input type="checkbox"/>	<input type="checkbox"/>			
<p>103. Identify (circle) the <u>incorrect</u> use of the chain shortener</p>				<input type="checkbox"/>	<input type="checkbox"/>
<div style="display: flex; justify-content: space-around; align-items: center;"> <div style="text-align: center;">  <p>a</p> </div> <div style="text-align: center;">  <p>b</p> </div> <div style="text-align: center;">  <p>c</p> </div> </div>					

TLILIC0020 Licence to operate a slewing mobile crane (over 100 Tonnes)-ACTIVITY BOOK

Short Questions	S	NS	Short Questions	S	NS
<p>104. What is the purpose of checking all lifting equipment before use?</p> <p>.....</p> <p>.....</p>	<input type="checkbox"/>	<input type="checkbox"/>	<p>105. What information must be clearly and permanently marked on a shackle body?</p> <p><i>Provide three (3) examples</i></p> <p>.....</p> <p>.....</p> <p>.....</p> <p>.....</p>	<input type="checkbox"/>	<input type="checkbox"/>
<p>106. What checks should be made to shackles before any lifting use occurs?</p> <p><i>Provide four examples</i></p> <p>.....</p> <p>.....</p> <p>.....</p> <p>.....</p>	<input type="checkbox"/>	<input type="checkbox"/>	<p>107. What should be placed at the landing area in order to stop a concrete pipe from rolling away?</p> <p>.....</p> <p>.....</p>	<input type="checkbox"/>	<input type="checkbox"/>
<p>108. What checks should be made to the load landing area?</p> <ul style="list-style-type: none"> a. Stability of the surface b. The capacity of the surface to bear the load weight c. Safe access d. Exclusion zones (isolation of pedestrian and or traffic) e. All the above 	<input type="checkbox"/>	<input type="checkbox"/>	<p>109. What are four (4) safety considerations you should make before performing lifts?</p> <p>.....</p> <p>.....</p> <p>.....</p> <p>.....</p>	<input type="checkbox"/>	<input type="checkbox"/>

TLILIC0020 Licence to operate a slewing mobile crane (over 100 Tonnes)-ACTIVITY BOOK

Short Questions	S	NS	Short Questions	S	NS
<p>110. What is your responsibility regarding load weight as the crane operator?</p> <p>.....</p> <p>.....</p> <p>.....</p>	<input type="checkbox"/>	<input type="checkbox"/>	<p>111. Why should the hoist limit not be exceeded?</p> <p>.....</p> <p>.....</p> <p>.....</p>	<input type="checkbox"/>	<input type="checkbox"/>
<p>112. Under what conditions would side slope deration be applied?</p> <p>a. When driving on a hard road surface</p> <p>b. Any deviation from the firm-level ground will require the rated capacity to be reduced as per manufacturer specifications</p> <p>c. When the winch drum is labouring</p> <p>d. None of the above</p>	<input type="checkbox"/>	<input type="checkbox"/>			

TLILIC0020 Licence to operate a slewing mobile crane (over 100 Tonnes)-ACTIVITY BOOK

Short Questions	S	NS	Short Questions	S	NS		
<p>113. Complete the following questions</p> <div style="border: 1px solid black; padding: 10px; margin: 10px 0;"> <p>What would you do if the load chart failed to show the exact working radius?</p> <p>.....</p> <p>Why?</p> <p>.....</p> </div> <div style="border: 1px solid black; padding: 10px; margin: 10px 0;"> <p>Prior to lifting a load, what must you be aware of to ensure you will be working within the cranes operating radius?</p> <p><i>Provide three examples</i></p> <p>.....</p> <p>.....</p> <p>.....</p> </div>			<input type="checkbox"/>	<input type="checkbox"/>		<input type="checkbox"/>	<input type="checkbox"/>
<p>114. How can you position a lifting hook over the loads centre of gravity, why is this done?</p> <p>.....</p> <p>.....</p> <p>.....</p>	<input type="checkbox"/>	<input type="checkbox"/>	<p>115. How can you ensure a load with a strange centre of gravity has been slung correctly?</p> <p>.....</p> <p>.....</p>	<input type="checkbox"/>	<input type="checkbox"/>		

TLILIC0020 Licence to operate a slewing mobile crane (over 100 Tonnes)-ACTIVITY BOOK

Short Questions	S	NS	Short Questions	S	NS
<p>116. How can you use lifting gear safely?</p> <p>a. Always ensure the load weight does not exceed the limitations of lifting gear</p> <p>b. Connect lifting gear to the load according to the lifting plan</p> <p>c. Follow safe work procedures and equipment manufacturer specifications</p> <p>d. All the above</p>	<input type="checkbox"/>	<input type="checkbox"/>	<p>117. What should you refer to for instructions on configuring the crane to mobile a load?</p> <p>.....</p> <p>.....</p> <p>.....</p>	<input type="checkbox"/>	<input type="checkbox"/>
<p>118. What is the purpose of a test lift?</p> <p><i>Provide four (4) examples</i></p> <p>.....</p> <p>.....</p> <p>.....</p> <p>.....</p>	<input type="checkbox"/>	<input type="checkbox"/>	<p>119. What would you do if you run into issues doing a test lift?</p> <p>.....</p> <p>.....</p> <p>.....</p> <p>.....</p> <p>.....</p> <p>.....</p>	<input type="checkbox"/>	<input type="checkbox"/>

TLILIC0020 Licence to operate a slewing mobile crane (over 100 Tonnes)-ACTIVITY BOOK

Short Questions	S	NS	Short Questions	S	NS
<p>120. Complete the following questions</p> <div style="border: 1px solid black; padding: 10px; margin: 10px 0;"> <p>What is the function of a tagline?</p> <p>.....</p> </div> <div style="border: 1px solid black; padding: 10px; margin: 10px 0;"> <p>What is the smallest diameter tagline you may use and what should it be made of?</p> <p>.....</p> </div>				<input type="checkbox"/>	<input type="checkbox"/>
<p>121. What types of temporary rope connections can be used when connecting a tagline to a load?</p> <p>a. Clove hitch</p> <p>b. Rolling hitch</p> <p>c. Single sheet bend</p> <p>d. Bowline</p> <p>e. All the above</p>	<input type="checkbox"/>	<input type="checkbox"/>	<p>122. What effect could fast or jerky movements have on the crane and load?</p> <p>a. Load swing can increase the operating radius to a dangerous length</p> <p>b. This could result in instability or structural damage to the crane</p> <p>c. None of the above</p>	<input type="checkbox"/>	<input type="checkbox"/>
<p>123. List two (2) reasons why you should never drag or snig a load.</p> <p>.....</p> <p>.....</p>	<input type="checkbox"/>	<input type="checkbox"/>	<p>124. Why should a crane driver constantly monitor the load movement?</p> <p>.....</p> <p>.....</p> <p>.....</p> <p>.....</p>	<input type="checkbox"/>	<input type="checkbox"/>

TLILIC0020 Licence to operate a slewing mobile crane (over 100 Tonnes)-ACTIVITY BOOK

Short Questions	S	NS	Short Questions	S	NS
<p>125. List five (5) safety considerations before travelling up a slope with a suspended load.</p> <p>.....</p> <p>.....</p> <p>.....</p> <p>.....</p> <p>.....</p>	<input type="checkbox"/>	<input type="checkbox"/>	<p>126. How will slewing the boom from the front to the back of the vehicle influence the crane capacity, how can you obtain information about this?</p> <p>.....</p> <p>.....</p>	<input type="checkbox"/>	<input type="checkbox"/>

TLILIC0020 Licence to operate a slewing mobile crane (over 100 Tonnes)-ACTIVITY BOOK

Short Questions

S







NS

Short Questions

S

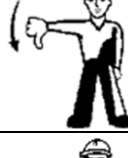
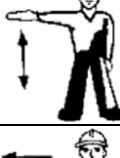
NS

127. Write in the missing signal, meaning and whistle.

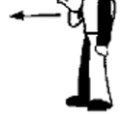
Hand Signal	Meaning	Whistle
		
		
		
		
		
		
		
		
		

TLILIC0020 Licence to operate a slewing mobile crane (over 100 Tonnes)-ACTIVITY BOOK

Short Questions	S	NS	Short Questions	S	NS
<p>128. What would you do if you fail to understand a signal during crane operations?</p> <p>.....</p> <p>.....</p> <p>.....</p>	<input type="checkbox"/>	<input type="checkbox"/>	<p>129. How do you reduce upwards boom/jib movement after landing a heavy load from the hook?</p> <p>.....</p> <p>.....</p> <p>.....</p> <p>.....</p> <p>.....</p> <p>.....</p> <p>.....</p>	<input type="checkbox"/>	<input type="checkbox"/>
<p>130. What is the purpose of using packing or dunnage when landing loads?</p> <p><i>Provide four (4) examples</i></p> <p>.....</p> <p>.....</p> <p>.....</p> <p>.....</p>	<input type="checkbox"/>	<input type="checkbox"/>			

TLILIC0020 Licence to operate a slewing mobile crane (over 100 Tonnes)-ACTIVITY BOOK

Short Questions	S	NS	Short Questions	S	NS
<p>131. Complete the following questions</p>				<input type="checkbox"/>	<input type="checkbox"/>
<p>What defects will indicate that a synthetic sling is unsafe for lifting purposes?</p> <p><i>Provide seven examples</i></p> <p>.....</p> <p>.....</p> <p>.....</p> <p>.....</p> <p>.....</p> <p>.....</p> <p>.....</p>					
<p>What defects will indicate that a wire rope sling is unsafe for lifting purposes?</p> <p><i>Provide seven examples</i></p> <p>.....</p> <p>.....</p> <p>.....</p> <p>.....</p> <p>.....</p> <p>.....</p> <p>.....</p>					

TLILIC0020 Licence to operate a slewing mobile crane (over 100 Tonnes)-ACTIVITY BOOK

Short Questions	S	NS	Short Questions	S	NS
-----------------	---	----	-----------------	---	----

132. Complete the following questions

<input type="checkbox"/>	<input type="checkbox"/>
--------------------------	--------------------------

What defects will indicate that shackles are unsafe for lifting purposes?

Provide four examples

.....

.....

.....

.....

What defects will indicate that lifting chains are unsafe for lifting purposes?

Provide seven examples

.....

.....

.....

.....

.....

.....

.....

TLILIC0020 Licence to operate a slewing mobile crane (over 100 Tonnes)-ACTIVITY BOOK

Short Questions	S	NS	Short Questions	S	NS
<p>133. What action would you take if you identified any defects to lifting equipment or gear?</p> <p>a. Isolate defective equipment b. Tag out c. Report and record d. All the above</p>	<input type="checkbox"/>	<input type="checkbox"/>	<p>134. What is required when stowing or securing the boom/jib or any lifting equipment?</p> <p>a. Secure correctly according to manufacturer requirements b. Locking pins as required c. Both a & b are correct</p>	<input type="checkbox"/>	<input type="checkbox"/>
<p>135. Where and how would you store synthetic lifting equipment?</p> <p><i>Provide six examples</i></p> <p>.....</p> <p>.....</p> <p>.....</p> <p>.....</p> <p>.....</p> <p>.....</p>	<input type="checkbox"/>	<input type="checkbox"/>	<p>136. What is required where a fly jib or counterweight is removed to a storage position?</p> <p>a. Securing according to manufacturer requirements b. Exclusion zones and barricading to prevent any damage occurring when stored on-site at ground level c. Both a and b where applicable</p>	<input type="checkbox"/>	<input type="checkbox"/>
<p>137. When are motion locks and brakes used?</p> <p>.....</p> <p>.....</p> <p>.....</p>	<input type="checkbox"/>	<input type="checkbox"/>	<p>138. How would you stow outriggers when shutting down a crane?</p> <p>a. Retract all outriggers b. Lock them in with the correct pins c. According to manufacturer/workplace requirements d. All the above</p>	<input type="checkbox"/>	<input type="checkbox"/>

TLILIC0020 Licence to operate a slewing mobile crane (over 100 Tonnes)-ACTIVITY BOOK

Short Questions	S	NS	Short Questions	S	NS
<p>139. What steps should be done when a crane will be left unattended until the following day? <i>Provide four (4) examples</i></p> <p>.....</p> <p>.....</p> <p>.....</p> <p>.....</p> <p>.....</p>	<input type="checkbox"/>	<input type="checkbox"/>	<p>140. Why wouldn't you leave a load hanging on a hook after shutdown?</p> <p>.....</p> <p>.....</p> <p>.....</p> <p>.....</p>	<input type="checkbox"/>	<input type="checkbox"/>
<p>141. What checks must be done when shutting down and packing up a crane? <i>Provide seven examples</i></p> <p>.....</p> <p>.....</p> <p>.....</p> <p>.....</p> <p>.....</p> <p>.....</p> <p>.....</p> <p>.....</p>	<input type="checkbox"/>	<input type="checkbox"/>	<p>142. What are three (3) routine checks done after the crane shutdown?</p> <p>.....</p> <p>.....</p> <p>.....</p>	<input type="checkbox"/>	<input type="checkbox"/>

Calculation questions

S

NS

Q2. The Grove crane used in question 1 will now be relocated to an area of the site where it will be setup on loose sand.

What is the minimum outrigger pad area to prevent the crane sinking in the loose sand when using the same crane and outrigger configuration in question 1?

Note: student to (round up 0.1m)

Ground type	Max permissible ground pressure, Pmax (Tonnes per m ²)
Hard rock	200
Shale rock and sandstone	80
Compacted gravel (with up to 20% sand)	40
Asphalt	20
Compacted sand	20
Stiff clay (dry)	20
Soft clay (dry)	10
Loose sand	10
Wet clay	Less than 10

Complete in tonnes and meters

Calculation questions S NS

Q3. You need to setup the **Grove GMK 5130-2** crane on a new site

- The crane will be configured with **23.5t** counterweight, **3 parts of line** and 20t hook block
- You will extend the boom **50.71m**

a) What is the counterweight configuration required to achieve counterweight of 23.5tonnes?

Quantity	Counterweight	Weight (T)
	Total	

b) What is the maximum and minimum working radius in this boom configuration?

c) What is the maximum speed the hook block can be raised in the above boom configuration?

Calculation questions	S	NS																								
<p>Q5. You will use a Kobelco CKE2500 crawler crane</p> <ul style="list-style-type: none"> The crane has been configured in luffing jib configuration Boom length 27.4m Jib length 33.5m <p>a) What are the most flexible configurations for the boom and jib arrangements?</p> <table border="1" style="margin-left: 40px;"> <thead> <tr> <th colspan="6" style="background-color: #cccccc;">Boom arrangements (Lengths)</th> </tr> </thead> <tbody> <tr> <td style="width: 15%;"></td> <td style="width: 15%;"></td> <td style="width: 15%;"></td> <td style="width: 15%;"></td> <td style="width: 15%;"></td> <td style="width: 15%;"></td> </tr> </tbody> </table> <table border="1" style="margin-left: 40px;"> <thead> <tr> <th colspan="6" style="background-color: #cccccc;">Jib arrangements (Lengths)</th> </tr> </thead> <tbody> <tr> <td style="width: 15%;"></td> <td style="width: 15%;"></td> <td style="width: 15%;"></td> <td style="width: 15%;"></td> <td style="width: 15%;"></td> <td style="width: 15%;"></td> </tr> </tbody> </table> <p>b) What is the total counterweight required for the configuration?</p> <p>c) How many falls of rope should be on the hook block?</p>	Boom arrangements (Lengths)												Jib arrangements (Lengths)												<input type="checkbox"/>	<input type="checkbox"/>
Boom arrangements (Lengths)																										
Jib arrangements (Lengths)																										

Calculation questions	S	NS
<p>Q6: Use the Kobelco crawler crane configuration from the previous question (5)</p> <ul style="list-style-type: none"> You are required to pick up a 5-tonne load (including rigging) at a 24m radius and place it at a 45m radius <div style="border: 1px solid black; padding: 5px; margin-top: 10px;"> <p>a) What main boom angle is required to pick up the load vertically?</p> </div> <div style="border: 1px solid black; padding: 5px; margin-top: 10px;"> <p>b) Can you complete the operation in one single lift?</p> </div>	<input type="checkbox"/>	<input type="checkbox"/>

Calculation questions

S NS

Q7: A drum must be lifted using two vertical flexible steel wire ropes (FSWR) connected to a spreader bar

- The weight of the load is 1500kg evenly distributed between the lifting points

What is the minimum Working Load Limit necessary for each directly loaded sling leg?

Show all your calculations



Using the load chart provided, what is the minimum diameter sling required when the slings are directly loaded?

WIRE ROPE DIA. mm	CHOKE HITCH			DIRECT LOAD				CHOKE HITCH				BASKET HITCH				
	DIRECT LOAD	ROUND LOAD	RECTANGULAR LOAD	ROUND LOAD			OTHER THAN ROUND LOAD		ROUND LOAD		OTHER THAN ROUND LOAD					
				SINGLE WRAP	DOUBLE WRAP	SINGLE WRAP	DOUBLE WRAP	SINGLE WRAP	DOUBLE WRAP	SINGLE WRAP	DOUBLE WRAP					
												0° - 60°	90°	120°	0° - 45°	0° - 60°
MAXIMUM WORKING LOAD LIMITS IN TONNES OF 1000kg for 1570 GRADE FIBRE CORE - GALVANISED																
8	0.55	0.41	0.27	0.94	0.77	0.55	0.71	0.48	1.09	0.94	0.77	0.55	0.55	0.48	0.39	0.27
9	0.69	0.52	0.34	1.19	0.97	0.69	0.90	0.60	1.38	1.19	0.97	0.69	0.69	0.60	0.49	0.34
10	0.85	0.64	0.43	1.47	1.20	0.85	1.11	0.74	1.70	1.47	1.20	0.85	0.85	0.74	0.61	0.43
11	1.03	0.77	0.52	1.78	1.45	1.03	1.34	0.90	2.1	1.78	1.45	1.03	1.03	0.90	0.73	0.52
12	1.23	0.92	0.61	2.1	1.73	1.23	1.59	1.07	2.5	2.1	1.73	1.23	1.23	1.07	0.87	0.61
13	1.44	1.08	0.72	2.5	2.0	1.44	1.87	1.25	2.9	2.5	2.0	1.44	1.44	1.25	1.02	0.72
14	1.67	1.25	0.83	2.9	2.4	1.67	2.2	1.45	3.3	2.9	2.4	1.67	1.67	1.45	1.19	0.83
16	2.2	1.64	1.09	3.8	3.1	2.2	2.8	1.90	4.4	3.8	3.1	2.2	2.2	1.90	1.55	1.09
18	2.8	2.1	1.38	4.8	3.9	2.8	3.6	2.4	5.5	4.8	3.9	2.8	2.8	2.4	1.97	1.38
20	3.4	2.6	1.70	5.9	4.8	3.4	4.4	3.0	6.8	5.9	4.8	3.4	3.4	3.0	2.4	1.70
22	4.1	3.1	2.1	7.1	5.8	4.1	5.4	3.6	8.3	7.1	5.8	4.1	4.1	3.6	2.9	2.1
24	4.9	3.7	2.5	8.5	6.9	4.9	6.4	4.3	9.8	8.5	6.9	4.9	4.9	4.3	3.5	2.5
26	5.8	4.3	2.9	10.0	8.1	5.8	7.5	5.0	11.5	10.0	8.1	5.8	5.8	5.0	4.1	2.9
28	6.7	5.0	3.3	11.6	9.4	6.7	8.7	5.8	13.4	11.6	9.4	6.7	6.7	5.8	4.7	3.3
32	8.7	6.5	4.4	15.1	12.3	8.7	11.3	7.6	17.4	15.1	12.3	8.7	8.7	7.6	6.2	4.4

Calculation questions

S

NS

Q8: The task requires a container with lifting lugs to be relocated

- The angle between diagonally opposite sling legs is 60 degrees
- Grade T (80) chain slings will be used
- The chain diameter is 13mm

Using the sling tag provided, what is the maximum load weight that can be lifted?

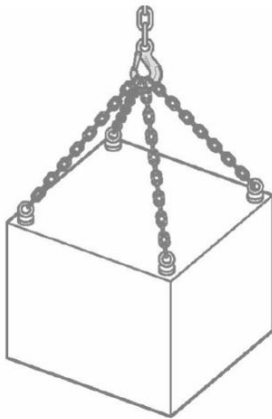

Calculation questions

S

NS



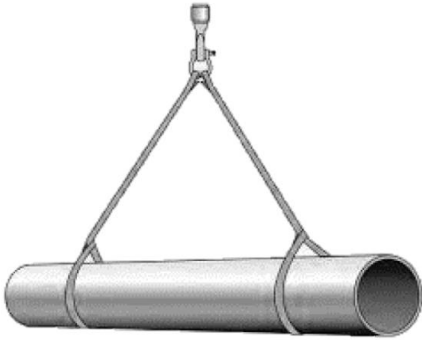





Q9: The task requires a cast iron pipe to be lifted



- Two synthetic slings are used to lift cast iron pipe
- The angle between slings is 60 degrees
- Pipe weight is 104kg per lineal metre
- The pipe length is 6.5m

What is the total pipe weight?

Using the pipe weight, what sling is the minimum required?

For educational purposes only									
		L = 1.0	L = 0.8	L = 2.0	L = 1.7	L = 1.4	L = 1.0	L = 1.7	L = 1.38
	L = LOAD FACTOR	L = 1.0	L = 0.8	L = 2.0	L = 1.7	L = 1.4	L = 1.0	L = 1.7	L = 1.38
Colour	W.L.L Tonnes	VERTICAL W.L.L Tonnes	CHOKE W.L.L Tonnes	BASKET W.L.L Tonnes	60° W.L.L Tonnes	90° W.L.L Tonnes	120° W.L.L Tonnes	60° W.L.L Tonnes	60° CHOKE W.L.L Tonnes
Violet	1.0	1.0	0.8	2.0	1.7	1.4	1.0	1.7	1.3
Green	2.0	2.0	1.6	4.0	3.4	2.8	2.0	3.4	2.7
Yellow	3.0	3.0	2.4	6.0	5.1	4.2	3.0	5.1	4.1
Grey	4.0	4.0	3.2	8.0	6.9	5.6	4.0	6.9	5.5
Red	5.0	5.0	4.0	10.0	8.6	7.0	5.0	8.6	6.9
Brown	6.0	6.0	4.8	12.0	10.3	8.4	6.0	10.3	8.2
Blue	8.0	8.0	6.4	16.0	13.8	11.2	8.0	13.8	11.0
Orange	10.0	10.0	8.0	20.0	17.3	14.1	10.0	17.3	13.8