



**CPCCLRG3002**

**Licence to perform rigging intermediate level**

**STUDENT ACTIVITY BOOK**

Student full name	
Date:	

## CPCCLRG3002 Licence to perform rigging intermediate level

This unit specifies the skills and knowledge required to safely perform intermediate rigging work.

Riggers use mechanical load shifting equipment and associated gear to move, place or secure loads, including plant, equipment or members of a building or structure. Riggers ensure the stability of those members and set up and dismantle cranes and hoists.

This unit includes rigging work involving:

- hoists with jibs and self-climbing hoists
- cranes, conveyors, dredges and excavators
- tilt slabs
- demolition of structures or plant
- multiple lifts.

Rigging work is undertaken in construction and other industries where load shifting equipment is used to move, place or secure loads.

Completion of the general construction induction training program, specified in the Safe Work Australia model Code of Practice: Construction Work, is required by anyone carrying out construction work. Achievement of CPCCWHS1001 Prepare to work safely in the construction industry meets this requirement.

This unit has a pre-requisite requirement. This requirement may be met by either the successful completion of the unit CPCCLRG3001 Licence to perform rigging basic level or holding a valid licence for basic rigging.

Competence in this unit does not in itself result in a licence. A licence is obtained after competence is assessed under applicable Commonwealth, state or territory work health and safety (WHS) regulations.

## STUDENT ACTIVITY BOOK

### STUDENT RECORD OF TRAINING - Student Details

Student full name:			
<p><b>DECLARATION</b> - I declare that the information contained in this application is true and correct and that all documents are genuine. Photo ID must also be provided with this application. V= Verbal clarification – I agree that all questions with a V on them have been discussed and verbally clarified with me by the Trainer/Assessor.</p>			
Student signature			
<b>Trainer/Assessor</b>			
Activity book	<b>Satisfactory</b> <input type="checkbox"/>	<b>Not satisfactory</b> <input type="checkbox"/>	
Trainer/Assessor Name			
Trainer/Assessor Signature		Date	
Trainer/Assessor comments			

## Student Introduction, Instructions & Guidelines

---

### Application

This unit specifies the skills and knowledge required to safely perform intermediate rigging work.

Riggers use mechanical load shifting equipment and associated gear to move, place or secure loads, including plant, equipment or members of a building or structure. Riggers ensure the stability of those members and set up and dismantle cranes and hoists.

This unit includes rigging work involving:

- hoists with jibs and self-climbing hoists
- cranes, conveyors, dredges and excavators
- tilt slabs
- demolition of structures or plant
- multiple lifts.

Rigging work is undertaken in construction and other industries where load shifting equipment is used to move, place or secure loads.

Completion of the general construction induction training program, specified in the Safe Work Australia model Code of Practice: Construction Work, is required by anyone carrying out construction work. Achievement of CPCWHS1001 Prepare to work safely in the construction industry meets this requirement.

This unit has a pre-requisite requirement. This requirement may be met by either the successful completion of the unit CPCCLRG3001 Licence to perform rigging basic level or holding a valid licence for basic rigging.

**Competence in this unit does not in itself result in a licence. A licence is obtained after competence is assessed under applicable Commonwealth, state or territory work health and safety (WHS) regulations.**

Welcome to the assessment of **CPCCLRG3002 Licence to perform rigging intermediate level**. During this assessment, you will work through a Theory Assessment and Practical Assessment with observable tasks. These activities will give you an understanding of this unit.

**Elements covered in this assessment are:**

1. Plan task.
2. Select and inspect equipment.
3. Set up task.
4. Undertake intermediate rigging activities.
5. Complete task.

### Understanding the Assessment

During your training, you will be observed working in various areas of your establishment. You will be assessed on your knowledge, skills and attitude whilst working in these areas. To be successful you must demonstrate competency on an ongoing basis. When you feel confident in a task you have undertaken or are about to undertake, notify your Trainer/Assessor so they can observe you during the task.

**You may be assessed in any number of ways:**

- You may be asked to explain how to undertake a given task
- You may be observed while carrying out a task
- You may be questioned on your ability to achieve the specified outcome
- You may have to complete various written tasks

Your Trainer/Assessor will carry out these assessments and you will be given notice as to when each assessment will take place. **To complete your assessment for each unit, you must complete all theory and practical assessment pieces to the required standard.**

**This unit is to be assessed by Theory Assessment and Practical assessment.**

- 1. Training and Theory assessment– minimum of 16 hrs Theory** - *This is an open activity book inclusive of multiple choice and written responses Activity book -short questions, done in class with the Trainer/Assessor. 100% accuracy to be achieved including any verbal responses. Theory assessment - Knowledge test - closed book 100% accuracy to be achieved.*
- 2. Training and Practical Assessment –** by observation- Trainer/Assessor and the Student is given a minimum **20 hrs** to complete the Practical. *Practical Assessments will include oral questions and observation of the person performing the tasks. Practical Assessments are to be conducted in the work environment wherever possible.*
- 3. Mandated Assessment Instrument** - closed book

## **STUDENT INSTRUCTIONS**

1. This is an open activity book
2. All questions to be attempted
3. Blue/black pen only to be used
4. Discussion with other Students is permitted during activity book
5. Assistance from the assessor may be requested to clarify a question
6. All questions must be answered correctly to be successful
7. All errors made by the student to be initialled by the student
8. The assessor may ask verbal questions to clarify points to be successful
9. When you have finished the activity book, complete the coversheet and hand all to your assessor
10. More than one multiple choice answer may be correct

## **REASONABLE ADJUSTMENT**

If you have any special needs that your assessor does not know about, you should let them know as soon as possible before starting any assessment so that your assessor can make changes where possible.

## **COMPETENT**

To be found competent in this unit of competency, you must 'satisfactorily' complete all assessment instruments and be assessed as competent in both the Theory and the Practical assessment.

## **FEEDBACK**

After an assessment, your assessor should give you feedback to let you know how you went and will discuss reassessment opportunities with you if needed. This feedback, along with the assessment result, will be recorded by your assessor on the front page of this assessment.

## **APPEALS ASSESSMENT**

All Students have the right to appeal an assessment if you feel you have not been fairly assessed in either the theory or the practical for this unit. This may include a reassessment or, you can make an appeal by completing our complaints and appeals form. You can find more information about appeals in the student handbook

## **REASSESSMENT**

All Students have the right to be reassessed. You will need to discuss this option with your Trainer/Assessor. Reassessment may include further training, resit the theory assessment or practical assessment. Guidelines depend on the regulator requirements for example re assessed on the day.

**CPCCLRG3002 Licence to perform rigging intermediate level - ACTIVITY BOOK**

Short Questions	S	NS	Short Questions	S	NS
<p><b>1. How can you obtain workplace information and or procedures including emergency plans?</b></p> <p>a. Site safety plan  b. Site induction  c. Site office  d. Contact site supervisor or foreman  e. None of the above</p>	<input type="checkbox"/>	<input type="checkbox"/>	<p><b>2. Why would you consult doggers, crane operators or other riggers when reviewing task instructions?</b></p> <p>a. Clarification if required  b. To ensure everyone understands the lift plan or task instructions  c. To ensure all persons understand their role  d. To confirm required communication signals  e. None of the above</p>	<input type="checkbox"/>	<input type="checkbox"/>
<p><b>3. What needs to be considered and planned for <u>other than hazards</u>, when planning for rigging activities?</b></p> <p><b><i>Provide six (6) examples</i></b></p> <p>.....</p> <p>.....</p> <p>.....</p> <p>.....</p> <p>.....</p> <p>.....</p> <p>.....</p>	<input type="checkbox"/>	<input type="checkbox"/>	<p><b>4. What must an employer provide, before you can perform new or unknown rigging activities?</b></p> <p><b><i>Provide three (3) examples</i></b></p> <p>.....</p> <p>.....</p> <p>.....</p>	<input type="checkbox"/>	<input type="checkbox"/>

**CPCCLRG3002 Licence to perform rigging intermediate level - ACTIVITY BOOK**

Short Questions	S	NS	Short Questions	S	NS
<p><b>5. If a high-risk worker is not working safely under a high-risk work licence, what can the work health and safety regulator do?</b></p> <p><i>Provide three (3) examples</i></p> <p>.....</p> <p>.....</p> <p>.....</p>	<input type="checkbox"/>	<input type="checkbox"/>	<p><b>6. What obligations do employers have to ensure the health and safety of all workers?</b></p> <p><i>Provide four (4) examples</i></p> <p>.....</p> <p>.....</p> <p>.....</p> <p>.....</p>	<input type="checkbox"/>	<input type="checkbox"/>
<p><b>7. What duty of care do you have regarding the health and safety of yourself and others?</b></p> <p><i>Provide three (3) examples</i></p> <p>.....</p> <p>.....</p> <p>.....</p>	<input type="checkbox"/>	<input type="checkbox"/>	<p><b>8. What rigging tasks is an intermediate rigger licenced to conduct on a worksite?</b></p> <p><i>Provide five (5) examples</i></p> <p>.....</p> <p>.....</p> <p>.....</p> <p>.....</p> <p>.....</p>	<input type="checkbox"/>	<input type="checkbox"/>

**CPCCLRG3002 Licence to perform rigging intermediate level - ACTIVITY BOOK**

Short Questions	S	NS	Short Questions	S	NS
<p><b>9. What documents can help you obtain workplace safety information?</b>  <b>Provide four (4) examples</b></p> <p>.....</p> <p>.....</p> <p>.....</p> <p>.....</p>	<input type="checkbox"/>	<input type="checkbox"/>	<p><b>10. What is the purpose of completing a Safe Work Method Statement (SWMS)?</b></p> <p>a. Used to identify hazards</p> <p>b. Used to assess risk and document controls</p> <p>c. Used to manage hazards involved in tasks you intend to undertake</p> <p>d. Used to comply with safe work requirements</p> <p>e. All the above</p>	<input type="checkbox"/>	<input type="checkbox"/>
<p><b>11. What types of information will supply details on inspection, care and use of equipment?</b></p> <p>a. Australian standards</p> <p>b. Site general arrangement plan</p> <p>c. Environmental management plan</p> <p>d. Manufacturer specifications</p> <p>e. None of the above</p>	<input type="checkbox"/>	<input type="checkbox"/>			
<p><b>12. Briefly explain the meaning of the following terms</b></p> <div style="border: 1px solid black; padding: 5px; margin-top: 10px;"> <p><b>A Hazard</b></p> <p>.....</p> </div> <div style="border: 1px solid black; padding: 5px; margin-top: 10px;"> <p><b>A Risk</b></p> <p>.....</p> </div>				<input type="checkbox"/>	<input type="checkbox"/>

**CPCCLRG3002 Licence to perform rigging intermediate level - ACTIVITY BOOK**

Short Questions

S

NS

Short Questions

S

NS

13. What type of workplace hazards need to be considered prior to undertaking rigging activities?



*Provide six (6) examples of hazards and controls relevant to intermediate rigging activities*

**Structure or environment**

**Hazard**

**Control**

**Movement**

**Hazard**

**Control**

**Underground and overhead**

**Hazard**

**Control**

**Equipment**

**Hazard**

**Control**

**CPCCLRG3002 Licence to perform rigging intermediate level - ACTIVITY BOOK**

Short Questions	S	NS	Short Questions	S	NS
-----------------	---	----	-----------------	---	----

14. What are the missing controls from the hierarchy?

- a. Isolate, Hesitate, Personal protective equipment
- b. Eliminate, Isolate, Personal protective equipment
- c. Hesitate, Eliminate, Personal protective equipment
- d. None of the above

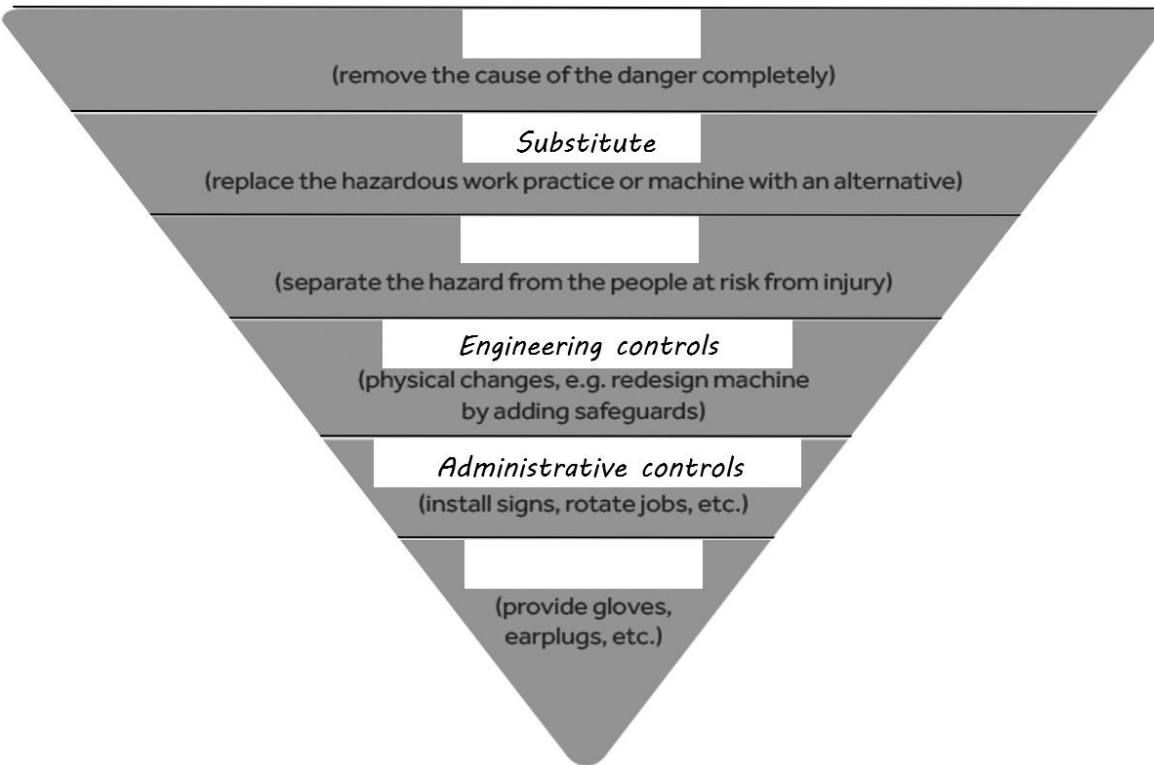

15. At what height is fall prevention or fall arrest equipment required?

- a. 2m or higher
- b. 1.5 m
- c. 3m and above
- d. 4m

16. How can you determine requirements or procedures for the use of personal protective equipment?

- a. Site induction
- b. Site signage
- c. Safety data sheets
- d. SWMS
- e. All the above

**CPCCLRG3002 Licence to perform rigging intermediate level - ACTIVITY BOOK**

Short Questions	S	NS	Short Questions	S	NS									
<p><b>17. What conditions would likely require the use of a tagline?</b></p> <p>a. The load suspended by the crane is likely to swing back and forth (due to wind or other external factors) creating a control hazard.</p> <p>b. The movement or rotation of the load causes a hazardous condition.</p> <p>c. To help orient a load for proper placement or connection upon landing</p> <p>d. All the above</p>	<input type="checkbox"/>	<input type="checkbox"/>	<p><b>18. What visual signs can help to identify the location of power lines on your worksite?</b></p> <p><i>Provide three (3) examples</i></p> <p>.....</p> <p>.....</p> <p>.....</p>	<input type="checkbox"/>	<input type="checkbox"/>									
<p><b>19. What distance is an unauthorised person required to maintain, when performing rigging, mobile plant operations or scaffolding activities near electric lines <u>in your state</u>?</b></p> <table border="1" style="margin-left: 20px;"> <tr> <td colspan="2"><b>QLD</b></td> </tr> <tr> <td>Up to 132,000v</td> <td></td> </tr> <tr> <td>132,000v to 220,000v</td> <td></td> </tr> <tr> <td>220,000v to 275,000v</td> <td></td> </tr> <tr> <td>Above 275,000v</td> <td></td> </tr> </table>			<b>QLD</b>		Up to 132,000v		132,000v to 220,000v		220,000v to 275,000v		Above 275,000v		<input type="checkbox"/>	<input type="checkbox"/>
<b>QLD</b>														
Up to 132,000v														
132,000v to 220,000v														
220,000v to 275,000v														
Above 275,000v														
<p><b>20. If necessary, how can you work closer than the prescribed safe operating distance for power lines?</b></p> <p><i>Provide three (3) examples</i></p> <p>.....</p> <p>.....</p> <p>.....</p> <p>.....</p>	<input type="checkbox"/>	<input type="checkbox"/>	<p><b>21. How should you respond to an unsafe incident or event that occurs during rigging operations?</b></p> <p>a. Stop and assess the unsafe situation</p> <p>b. Resolve the issue (if possible)</p> <p>c. Get advice and assistance where required</p> <p>d. Report the incident to the relevant authority and according to workplace procedures</p> <p>e. All the above</p>	<input type="checkbox"/>	<input type="checkbox"/>									

**CPCCLRG3002 Licence to perform rigging intermediate level - ACTIVITY BOOK**

Short Questions	S	NS	Short Questions	S	NS
<p><b>22. How can you safely carry tools when working on a ladder?</b></p> <ul style="list-style-type: none"> <li>a. In a toolbox and using two points of contact</li> <li>b. In a tool belt with load rated D-ring tether anchors</li> <li>c. In a tool bag with load rated D-ring tether anchors</li> <li>d. All the above</li> </ul>	<input type="checkbox"/>	<input type="checkbox"/>	<p><b>23. How can you reduce manual handling, when moving tools or materials into a work area?</b></p> <ul style="list-style-type: none"> <li>a. Use a materials hoist</li> <li>b. Use mobile plant equipment e.g., crane</li> <li>c. Use a gin wheel or an electric hoist</li> <li>d. All the above</li> </ul>	<input type="checkbox"/>	<input type="checkbox"/>
<p><b>24. How would you identify rigging equipment or any associated lifting gear required for a lift?</b></p> <ul style="list-style-type: none"> <li>a. From the lift plan</li> <li>b. SWMS</li> <li>c. Environmental management plan</li> <li>d. None of the above</li> </ul>	<input type="checkbox"/>	<input type="checkbox"/>	<p><b>25. What considerations should be made before selecting pipe clamps for use?</b></p> <ul style="list-style-type: none"> <li>a. Orientation of use</li> <li>b. Working Load Limit (WLL)</li> <li>c. Diameter of pipe</li> <li>d. Thickness of pipe</li> <li>e. All the above</li> </ul>	<input type="checkbox"/>	<input type="checkbox"/>
<p><b>26. What considerations should be made before selecting a lifting beam or spreader bar?</b></p> <ul style="list-style-type: none"> <li>a. Amount of available head room</li> <li>b. Whether the load will need to be evenly distributed across two lifting points above the bar</li> <li>c. Whether the load must be supported by multiple lifting points under the bar</li> <li>d. Whether a weak or flexible load that needs support will need to be lifted</li> <li>e. All the above</li> </ul>	<input type="checkbox"/>	<input type="checkbox"/>	<p><b>27. What considerations should be made before selecting chain rollers or load skates?</b></p> <ul style="list-style-type: none"> <li>a. Type of roller for the floor type to avoid floor damage and for rolling resistance</li> <li>b. Footprint and manoeuvrability (size of the object, path of required movement or need for steerable load skates)</li> <li>c. Tonnage (capacity of the load skate and duty of roller material)</li> <li>d. Tug assist or manual, towable handle or manual T bar</li> <li>e. All the above</li> </ul>	<input type="checkbox"/>	<input type="checkbox"/>

**CPCCLRG3002 Licence to perform rigging intermediate level - ACTIVITY BOOK**

Short Questions	S	NS	Short Questions	S	NS
<p><b>28. What checks should be performed on jacks prior to use?</b></p> <ul style="list-style-type: none"> <li>a. WLL exceeds that of the load to be lifted</li> <li>b. Condition of pawl, the teeth of the ratchet and the handle</li> <li>c. Release valve is operating satisfactorily</li> <li>d. Worn rams, pistons, or plungers</li> <li>e. Complies with Australian standards and functions as per manufacturer's original specifications</li> <li>f. All the above</li> </ul>	<input type="checkbox"/>	<input type="checkbox"/>	<p><b>29. What methods and or equipment can be used to fasten the tail of the hoist rope to the winch drum?</b></p> <ul style="list-style-type: none"> <li>a. Clamp and bolts</li> <li>b. Socket and wedge</li> <li>c. Wire rope grips</li> <li>d. Poured sockets</li> <li>e. All the above</li> </ul>	<input type="checkbox"/>	<input type="checkbox"/>
<p><b>30. What are the advantages of using a round turn and two half hitches?</b></p> <ul style="list-style-type: none"> <li>a. Can be tied quickly</li> <li>b. Can be tied under load</li> <li>c. Self-tightening</li> <li>d. Does not bind to the tying point making it simple to untie and can be undone under load</li> <li>e. All the above</li> </ul>	<input type="checkbox"/>	<input type="checkbox"/>			

**CPCCLRG3002 Licence to perform rigging intermediate level - ACTIVITY BOOK**

Short Questions

S

NS

Short Questions

S

NS

31. You are coordinating a multi-crane lift using the two cranes of same type at a fixed radius

- The share of the load being carried by **Crane 1** is 6 tonnes
- The share of the load being carried by **Crane 2** is 9 tonnes

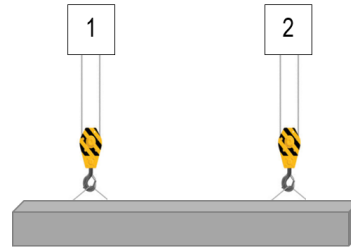

What is the minimum rated capacity required for each crane at the fixed radius throughout the lift?

Minimum crane 1 capacity

Minimum crane 2 capacity

Minimum rated capacity of crane 1

Minimum rated capacity of crane 2

**CPCCLRG3002 Licence to perform rigging intermediate level - ACTIVITY BOOK**

Short Questions

S

NS

Short Questions

S

NS

**32. You must conduct a multi-crane lift using four (4) cranes of same type at a fixed radius**



- The share of the load being carried by **Crane 1** is 12 tonnes
- The share of the load being carried by **Crane 2** is 17 tonnes
- The share of the load being carried by **Crane 3** is 22 tonnes
- The share of the load being carried by **Crane 4** is 27 tonnes

<b>Minimum crane 1 capacity</b>	<b>Minimum crane 2 capacity</b>
<b>Minimum crane 3 capacity</b>	<b>Minimum crane 4 capacity</b>
<b>Minimum rated capacity of crane 1</b>	
<b>Minimum rated capacity of crane 2</b>	
<b>Minimum rated capacity of crane 3</b>	
<b>Minimum rated capacity of crane 4</b>	

**CPCCLRG3002 Licence to perform rigging intermediate level - ACTIVITY BOOK**

Short Questions	S	NS	Short Questions	S	NS						
<p><b>33. Calculate the percentage of the load that each crane should be carrying given the following information</b></p> <ul style="list-style-type: none"> <li>• <b>Crane 1</b> has a maximum rated capacity of <u>36 tonnes</u></li> <li>• <b>Crane 2</b> has a maximum rated capacity of <u>25 tonnes</u></li> </ul> <p>The cranes will be used to lift an evenly distributed and balanced load that is symmetrical  <u>Load is 15 metres</u> in length and weighs <u>37 tonnes</u></p> <table border="1" data-bbox="135 627 1305 1120"> <tr> <td data-bbox="135 627 721 990">Percentage crane 1</td> <td data-bbox="721 627 1305 990">Percentage crane 2</td> </tr> <tr> <td colspan="2" data-bbox="135 990 1305 1057">The proportion (percentage) of the load to be carried by <u>crane 1</u> =</td> </tr> <tr> <td colspan="2" data-bbox="135 1057 1305 1120">The proportion (percentage) of the load to be carried by <u>crane 2</u> =</td> </tr> </table>	Percentage crane 1	Percentage crane 2	The proportion (percentage) of the load to be carried by <u>crane 1</u> =		The proportion (percentage) of the load to be carried by <u>crane 2</u> =					<input type="checkbox"/>	<input type="checkbox"/>
Percentage crane 1	Percentage crane 2										
The proportion (percentage) of the load to be carried by <u>crane 1</u> =											
The proportion (percentage) of the load to be carried by <u>crane 2</u> =											
<p><b>34. Calculate the load share (in tonnes), that crane 1 and crane 2 from the previous question should be carrying</b></p> <p>The cranes will be used to lift an evenly distributed and balanced load that is symmetrical  <u>Load is 15 metres</u> in length and weighs <u>37 tonnes</u></p> <table border="1" data-bbox="135 1433 1305 1971"> <tr> <td data-bbox="135 1433 721 1836">Load share <u>crane 1</u></td> <td data-bbox="721 1433 1305 1836">Load share <u>crane 2</u></td> </tr> <tr> <td colspan="2" data-bbox="135 1836 1305 1904">Load share to be carried by <u>crane 1</u> =</td> </tr> <tr> <td colspan="2" data-bbox="135 1904 1305 1971">Load share to be carried by <u>crane 2</u> =</td> </tr> </table>	Load share <u>crane 1</u>	Load share <u>crane 2</u>	Load share to be carried by <u>crane 1</u> =		Load share to be carried by <u>crane 2</u> =					<input type="checkbox"/>	<input type="checkbox"/>
Load share <u>crane 1</u>	Load share <u>crane 2</u>										
Load share to be carried by <u>crane 1</u> =											
Load share to be carried by <u>crane 2</u> =											





**CPCCLRG3002 Licence to perform rigging intermediate level - ACTIVITY BOOK**

Short Questions

S

NS

Short Questions

S

NS

38. Calculate the lengths of the slings required to lift the tilt panel below.

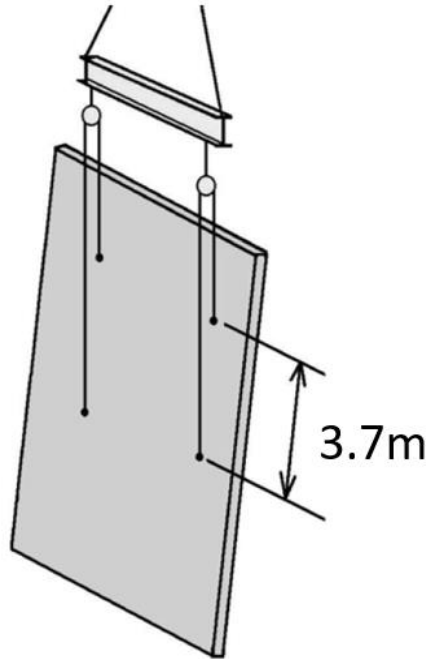
**Calculation method**

CPCCLRG3002 Licence to perform rigging intermediate level - ACTIVITY BOOK					
Short Questions	S	NS	Short Questions	S	NS
<p><b>39. You are required to make calculations relative to the felling of a concrete column, the column will be lowered</b></p> <ul style="list-style-type: none"> <li>• <b>Column dimensions 500mm square by 5.5 m high</b></li> <li>• FSWR and winch to be used</li> </ul>					
<p><b>Calculation method</b></p>					
<p><b>40. What weight should the winch in the previous question be able to support?</b></p>					
<p><b>Calculation method</b></p>					
<p><b>41. Determine horizontal distance between the pulling mechanism and the structure to be felled (concrete column)</b></p> <ul style="list-style-type: none"> <li>• <b>Column dimensions 500mm square by 5.5 m high</b></li> <li>• FSWR and winch to be used</li> </ul>					
<p><b>Calculation method to determine horizontal distance</b></p>					

**CPCCLRG3002 Licence to perform rigging intermediate level - ACTIVITY BOOK**

Short Questions	S	NS	Short Questions	S	NS
<b>42. Determine the distance to the wire rope that a person may stand during felling</b>				<input type="checkbox"/>	<input type="checkbox"/>
<div style="border: 1px solid black; padding: 10px; min-height: 150px;"> <p><b>Calculation method to determine distance to the sides of the wire rope</b></p> </div>					
<b>43. Why would you discuss communication methods and signals with other relevant personnel before starting work?</b>	<input type="checkbox"/>	<input type="checkbox"/>	<b>44. What communication methods are considered acceptable on a work site?</b> <i>Provide three (3) examples</i>	<input type="checkbox"/>	<input type="checkbox"/>
<ul style="list-style-type: none"> <li>a. Ensure appropriate methods are selected</li> <li>b. Ensure all personnel understand the signals to be used</li> <li>c. Avoid confusion</li> <li>d. All the above</li> </ul>			<p>.....</p> <p>.....</p> <p>.....</p>		
<b>45. When would you select a fall arrest system (energy absorber or inertia reel) as a suitable control method?</b>	<input type="checkbox"/>	<input type="checkbox"/>	<b>46. When are you required to check a safety harness or lanyard?</b>	<input type="checkbox"/>	<input type="checkbox"/>
<ul style="list-style-type: none"> <li>a. As your primary option</li> <li>b. When other risk controls are not feasible</li> <li>c. When working above 2m</li> <li>d. None of the above</li> </ul>			<ul style="list-style-type: none"> <li>a. Before and after each use</li> <li>b. Every six months by height safety equipment inspector</li> <li>c. Every 24 months</li> <li>d. None of the above</li> </ul>		

**CPCCLRG3002 Licence to perform rigging intermediate level - ACTIVITY BOOK**

Short Questions	S	NS	Short Questions	S	NS
<p>47. What will cause a lanyard or safety harness to become unsafe for use?</p> <p>a. Frayed or Split</p> <p>b. Chemical or UV damage</p> <p>c. Heat damage</p> <p>d. Out of date</p> <p>e. All the above</p>	<input type="checkbox"/>	<input type="checkbox"/>			

<p>48. You are required to inspect a rigging task in a work area with the following sign, what personal protective equipment should be selected for use?</p>	<input type="checkbox"/>	<input type="checkbox"/>
--	--------------------------	--------------------------



PPE equipment selected for use	
Hard hat	
Safety boots	
Gloves	
High-visibility clothing	
Hearing protection	
A hat, sight, or sun protection	
Dust mask	

**CPCCLRG3002 Licence to perform rigging intermediate level - ACTIVITY BOOK**

Short Questions	S	NS	Short Questions	S	NS
<p><b>49. When do you inspect safety equipment including personal protective equipment?</b></p> <p>a. Before and after any work            b. Only when it looks damaged            c. Only when told to do so            d. None of the above</p>	<input type="checkbox"/>	<input type="checkbox"/>	<p><b>50. What checks or inspections should be made to plate clamps prior to use?</b></p> <p>a. Inspect internal and external surfaces for fractures, wear and distortion            b. Check all pin holes for wear            c. Inspect the throat width. At zero grip, the cam should be in full contact with the pad            d. Measure the width of the throat, at the base and at the top, to check the measurement is the same            e. All the above</p>	<input type="checkbox"/>	<input type="checkbox"/>
<p><b>51. What checks should be made to a lever block or come-along prior to use?</b></p> <p>a. Inspect for damaged or deformed parts            b. No twists, kinks or stretched chain links            c. Check the retaining pawl engages correctly            d. Check the idling operation mode for excessive retaining plate and pawl rattle            e. Check brake functioning correctly            f. All the above</p>	<input type="checkbox"/>	<input type="checkbox"/>	<p><b>52. What types of checks would you perform on a snatch block prior to use?</b></p> <p>a. Wear, corrosion, cracks, nicks, gouges or deformation of hook or swivel tee            b. Wear, corrosion and damaged thrust washers of yoke assembly            c. Wear, at bolt and center pin bearing areas of load and center plate            d. Hook latch operation            e. All the above</p>	<input type="checkbox"/>	<input type="checkbox"/>
<p><b>53. What checks should be performed before using a chain block for lifting activities?</b></p> <p>a. Condition of the hand chain and load chain            b. Sheave wheels, hooks and outer casing            c. The mechanism and any safety devices for wear, nicks/cuts in chains, bent components, rust etc.            d. Hook safety latch in place and functional            e. All the above</p>	<input type="checkbox"/>	<input type="checkbox"/>	<p><b>54. What type of use can damage a shackle during lifting?</b></p> <p>a. Undersized shackle            b. Incorrect selection of shackle            c. Side loading            d. Exposing a shackle to heat            e. All the above</p>	<input type="checkbox"/>	<input type="checkbox"/>

**CPCCLRG3002 Licence to perform rigging intermediate level - ACTIVITY BOOK**

Short Questions	S	NS	Short Questions	S	NS
<p><b>55. What defects will indicate that a wire rope sling is unsafe for lifting purposes?</b></p> <p>a. Kinks, knotting, stretching, crushed</p> <p>b. Abrasion or corrosion</p> <p>c. Damage to eye</p> <p>d. All the above</p>	<input type="checkbox"/>	<input type="checkbox"/>	<p><b>56. What defects will indicate that chain slings are unsafe for lifting purposes?</b></p> <p>a. Twisted, kinked, knotted, stretched</p> <p>b. Cracked</p> <p>c. Missing tags</p> <p>d. Gouged or cut more than 10% of the original diameter</p> <p>e. All the above</p>	<input type="checkbox"/>	<input type="checkbox"/>
<p><b>57. What defects will indicate that a synthetic sling is unsafe for lifting purposes?</b></p> <p>a. Damage to stitching or sleeve</p> <p>b. Chemical damage or burns</p> <p>c. Cuts, tears or excessive wear and tear</p> <p>d. No label</p> <p>e. All the above</p>	<input type="checkbox"/>	<input type="checkbox"/>	<p><b>58. What checks should be made when inspecting a beam trolley before use?</b></p> <p>a. Structural check for deformation, cracks or excessive wear on any trolley parts including trolley wheels and bearings</p> <p>b. Loose or missing guards, fasteners, covers, stops or nameplates</p> <p>c. Check operating mechanisms to ensure normal operation occurs</p> <p>d. Supporting beam condition including clear of dirt or grit</p> <p>e. Labels and marking including WLL of the trolley for legibility</p> <p>f. All the above</p>	<input type="checkbox"/>	<input type="checkbox"/>
<p><b>59. What should you be aware of before connecting lifting gear to beam clamps?</b></p> <p>a. Rated capacity of the beam clamp is appropriate to the load</p> <p>b. Screw handle has been used to tighten the clamp securely to the beam</p> <p>c. That the beam flange is seated properly within the jaws</p> <p>d. All the above</p>	<input type="checkbox"/>	<input type="checkbox"/>	<p><b>60. What defects identify that a sheave is not safe for use?</b></p> <p>a. No WLL markings</p> <p>b. Flange cracked or chipped</p> <p>c. Groove or bearing worn</p> <p>d. Bending/warping</p> <p>e. All the above</p>	<input type="checkbox"/>	<input type="checkbox"/>

CPCCLRG3002 Licence to perform rigging intermediate level - ACTIVITY BOOK					
Short Questions	S	NS	Short Questions	S	NS
<p><b>61. Which of the following checks are required before a cantilevered crane loading platform can be used?</b></p> <ul style="list-style-type: none"> <li>a. Working Load Limit displayed</li> <li>b. Tare weight identified</li> <li>c. All bolts or connectors must be secured and tightened in position</li> <li>d. All props must be plumb and have the secure rear ties in position</li> <li>e. All the above</li> </ul>	<input type="checkbox"/>	<input type="checkbox"/>	<p><b>62. How would you determine the inspection, handling and storage requirements for safety screens or shutters?</b></p> <ul style="list-style-type: none"> <li>a. According to the manufacturer's specifications</li> <li>b. According to SWMS</li> <li>c. According to environmental management plan</li> <li>d. None of the above</li> </ul>	<input type="checkbox"/>	<input type="checkbox"/>
<p><b>63. What types of inspections and or records are required for an elevated work platform or mast climbing platform?</b></p> <ul style="list-style-type: none"> <li>a. Regular inspections as recommended by the manufacturer or competent person</li> <li>b. Pre-start inspection according to the manufacturer and workplace procedures</li> <li>c. Service and maintenance must be kept in a logbook or similar form</li> <li>d. All the above</li> </ul>	<input type="checkbox"/>	<input type="checkbox"/>	<p><b>64. What procedure would you follow, if you identify any lifting gear with missing tags or visible defects?</b></p> <ul style="list-style-type: none"> <li>a. Tag out</li> <li>b. Isolate</li> <li>c. Report</li> <li>d. Record</li> <li>e. None of the above</li> </ul>	<input type="checkbox"/>	<input type="checkbox"/>
<p><b>65. What checks should be made on a two-way radio before use?</b></p> <ul style="list-style-type: none"> <li>a. Visual defects</li> <li>b. Battery charged</li> <li>c. Channel setting</li> <li>d. Volume setting</li> <li>e. All the above</li> </ul>	<input type="checkbox"/>	<input type="checkbox"/>	<p><b>66. How can you ensure the task plan, risk controls and impact on other workplace activities are communicated to relevant personnel?</b></p> <ul style="list-style-type: none"> <li>a. Involve them in the task planning</li> <li>b. Involve them in the risk assessment process</li> <li>c. Establish and maintain communication throughout the entire work task</li> <li>d. All the above</li> </ul>	<input type="checkbox"/>	<input type="checkbox"/>

**CPCCLRG3002 Licence to perform rigging intermediate level - ACTIVITY BOOK**

Short Questions	S	NS	Short Questions	S	NS
<p><b>67. What risk controls are required when plant or structure is erected over a footpath?</b></p> <p>a. Warning signs and barriers b. Overhead protection c. Pedestrian exclusion zones d. All the above</p>	<input type="checkbox"/>	<input type="checkbox"/>	<p><b>68. What needs to be in place before conducting rigging activities in a low light environment?</b></p> <p>a. Exclusion zones b. Communication c. Adequate lighting d. None of the above</p>	<input type="checkbox"/>	<input type="checkbox"/>
<p><b>69. What is the advantage of using an open design rigging screw when attaching a static line to an eye bolt?</b></p> <p>a. Allows for visual inspection of threads b. Allows for longer applications c. Higher strength d. None of the above</p>	<input type="checkbox"/>	<input type="checkbox"/>	<p><b>70. What type of lever or device can be used to tension a static line?</b></p> <p>a. Turnbuckle b. Come-a-long winch c. Tirfor winch d. All the above</p>	<input type="checkbox"/>	<input type="checkbox"/>
<p><b>71. What methods are suitable to fasten the terminated ends of a wire rope static line?</b></p> <p>a. Double saddle clamps b. Suitable wedge sockets c. Machine splice with thimble eye d. Purpose designed fittings, such as swaged or pressed fittings e. All the above</p>	<input type="checkbox"/>	<input type="checkbox"/>			

**CPCCLRG3002 Licence to perform rigging intermediate level - ACTIVITY BOOK**

Short Questions	S	NS	Short Questions	S	NS																			
<b>72. Consider the following ground conditions and <u>select the four most suitable</u> to bear pressure</b>			<input type="checkbox"/> <input type="checkbox"/>																					
<table border="1"> <thead> <tr> <th colspan="2">Ground conditions</th> </tr> </thead> <tbody> <tr> <td>Soft / water impacted soil</td> <td></td> </tr> <tr> <td>Rough uneven ground</td> <td></td> </tr> <tr> <td>Shale rock</td> <td></td> </tr> <tr> <td>Sandstone</td> <td></td> </tr> <tr> <td>Compacted gravel with up to 20% sand</td> <td></td> </tr> <tr> <td>Backfilled ground</td> <td></td> </tr> <tr> <td>Hard rock</td> <td></td> </tr> <tr> <td>Bitumen</td> <td></td> </tr> <tr> <td>Hard compacted clay</td> <td></td> </tr> </tbody> </table>			Ground conditions		Soft / water impacted soil		Rough uneven ground		Shale rock		Sandstone		Compacted gravel with up to 20% sand		Backfilled ground		Hard rock		Bitumen		Hard compacted clay			
Ground conditions																								
Soft / water impacted soil																								
Rough uneven ground																								
Shale rock																								
Sandstone																								
Compacted gravel with up to 20% sand																								
Backfilled ground																								
Hard rock																								
Bitumen																								
Hard compacted clay																								
<b>73. How can you determine ground conditions including soil bearing capacity?</b>  .....  .....	<input type="checkbox"/>	<input type="checkbox"/>	<b>74. How would you determine the suitability of suspended concrete floors, a building roof or landing?</b>  a. Review the safety data sheets b. Review the site safety plan c. Consult with the engineer or see an engineering report d. None of the above	<input type="checkbox"/>	<input type="checkbox"/>																			
<b>75. What methods are used to ensure stability during structural steel erection?</b>  a. FSWR guys b. Fibre rope guys c. Plumbed using steel wedges if necessary d. Wind bracing bays erected e. None the above	<input type="checkbox"/>	<input type="checkbox"/>	<b>76. What document are you required to follow when demolishing a structure?</b>  .....  .....	<input type="checkbox"/>	<input type="checkbox"/>																			

**CPCCLRG3002 Licence to perform rigging intermediate level - ACTIVITY BOOK**

Short Questions	S	NS	Short Questions	S	NS
<p><b>77. What needs to be referred to, before a structure above a post-tensioned transfer beam can be demolished?</b></p> <p>.....</p> <p>.....</p>	<input type="checkbox"/>	<input type="checkbox"/>	<p><b>78. What is the consequence of shock loading during demolition activities?</b></p> <p><i>Provide three (3) examples</i></p> <p>.....</p> <p>.....</p> <p>.....</p>	<input type="checkbox"/>	<input type="checkbox"/>
<p><b>79. What crucial actions must be taken, where unexpected movement or overstressing of structural members becomes apparent?</b></p> <p>.....</p> <p>.....</p> <p>.....</p> <p>.....</p>	<input type="checkbox"/>	<input type="checkbox"/>	<p><b>80. How can you control the sudden shifting of a beam being freed during demolition work?</b></p> <p>.....</p>	<input type="checkbox"/>	<input type="checkbox"/>
<p><b>81. What safety factor is recommended for demolishing in-situ members by use of winches and rigging gear?</b></p> <p>.....</p>	<input type="checkbox"/>	<input type="checkbox"/>	<p><b>82. Identify the minimum allowable diameter of</b></p> <p><b>FSWR felling rope.....</b></p> <p><b>Grade 80 felling chain.....</b></p>	<input type="checkbox"/>	<input type="checkbox"/>

**CPCCLRG3002 Licence to perform rigging intermediate level - ACTIVITY BOOK**

Short Questions	S	NS	Short Questions	S	NS						
<p><b>83. What equipment could be used to suspend a person from a crane to perform a work task where no other means is suitable?</b></p> <p>a. Harness            b. Bottle cage            c. Brick or block cage            d. Personnel box, (workbox) that complies with the Australian standards</p>	<input type="checkbox"/>	<input type="checkbox"/>									
<p><b>84. Determine the additional capacities required for the following multiple crane lifts.</b></p> <table border="1" style="width: 100%; border-collapse: collapse;"> <tr> <td style="width: 40%; padding: 5px;">2 cranes are used for a lift</td> <td style="width: 60%;"></td> </tr> <tr> <td style="padding: 5px;">3 cranes are used for a lift</td> <td></td> </tr> <tr> <td style="padding: 5px;">4 or more cranes are used for a lift</td> <td></td> </tr> </table>				2 cranes are used for a lift		3 cranes are used for a lift		4 or more cranes are used for a lift		<input type="checkbox"/>	<input type="checkbox"/>
2 cranes are used for a lift											
3 cranes are used for a lift											
4 or more cranes are used for a lift											
<p><b>85. Why do you need a rated capacity indicator or load moment indicator when performing multi-crane lifts?</b></p> <p>.....</p> <p>.....</p>	<input type="checkbox"/>	<input type="checkbox"/>	<p><b>86. Why would you use a lifting beam, or other equalising equipment when two cranes will be used to support a load?</b></p> <p><i>Provide at least <u>two</u> examples</i></p> <p>.....</p> <p>.....</p> <p>.....</p> <p>.....</p> <p>.....</p>	<input type="checkbox"/>	<input type="checkbox"/>						

**CPCCLRG3002 Licence to perform rigging intermediate level - ACTIVITY BOOK**

Short Questions	S	NS	Short Questions	S	NS
<p><b>87. What should the rigger monitor or ensure, when coordinating a multiple crane lift?</b>  <b>Provide six (6) examples</b></p> <p>.....</p> <p>.....</p> <p>.....</p> <p>.....</p> <p>.....</p> <p>.....</p>	<input type="checkbox"/>	<input type="checkbox"/>	<p><b>88. What should the rigger ensure when coordinating a pick and carry multi-crane lift?</b>  <b>Provide four (4) examples</b></p> <p>.....</p> <p>.....</p> <p>.....</p> <p>.....</p>	<input type="checkbox"/>	<input type="checkbox"/>
<p><b>89. Why would it be hazardous to luff down during a multiple crane lift?</b></p> <p>.....</p> <p>.....</p> <p>.....</p> <p>.....</p>	<input type="checkbox"/>	<input type="checkbox"/>			

**CPCCLRG3002 Licence to perform rigging intermediate level - ACTIVITY BOOK**

Short Questions

S

NS

Short Questions

S

NS

90. Identify the luffing jib tower crane components

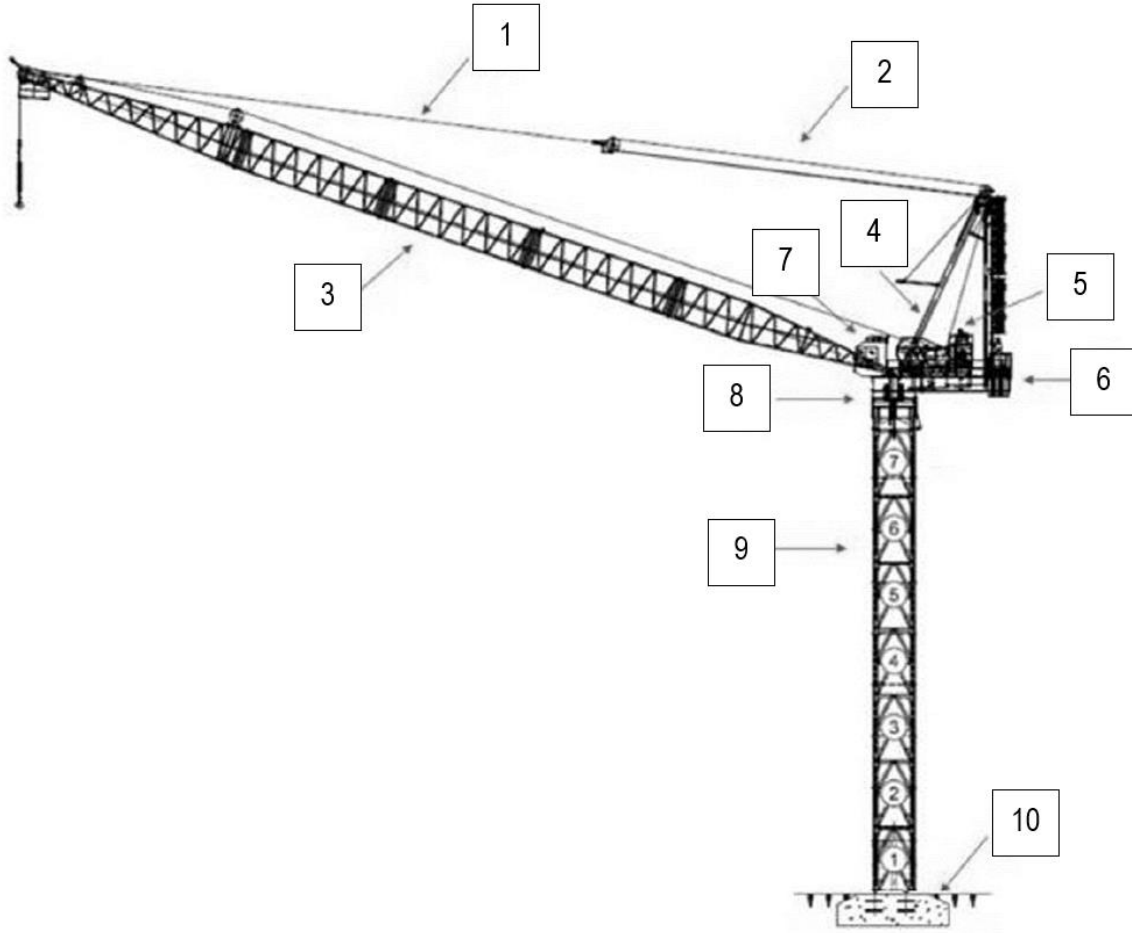
1	
2	
3	
4	
5	
6	
7	
8	
9	
10	

**CPCCLRG3002 Licence to perform rigging intermediate level - ACTIVITY BOOK**

Short Questions

S

NS

Short Questions

S

NS

91. Identify the hammerhead tower crane components

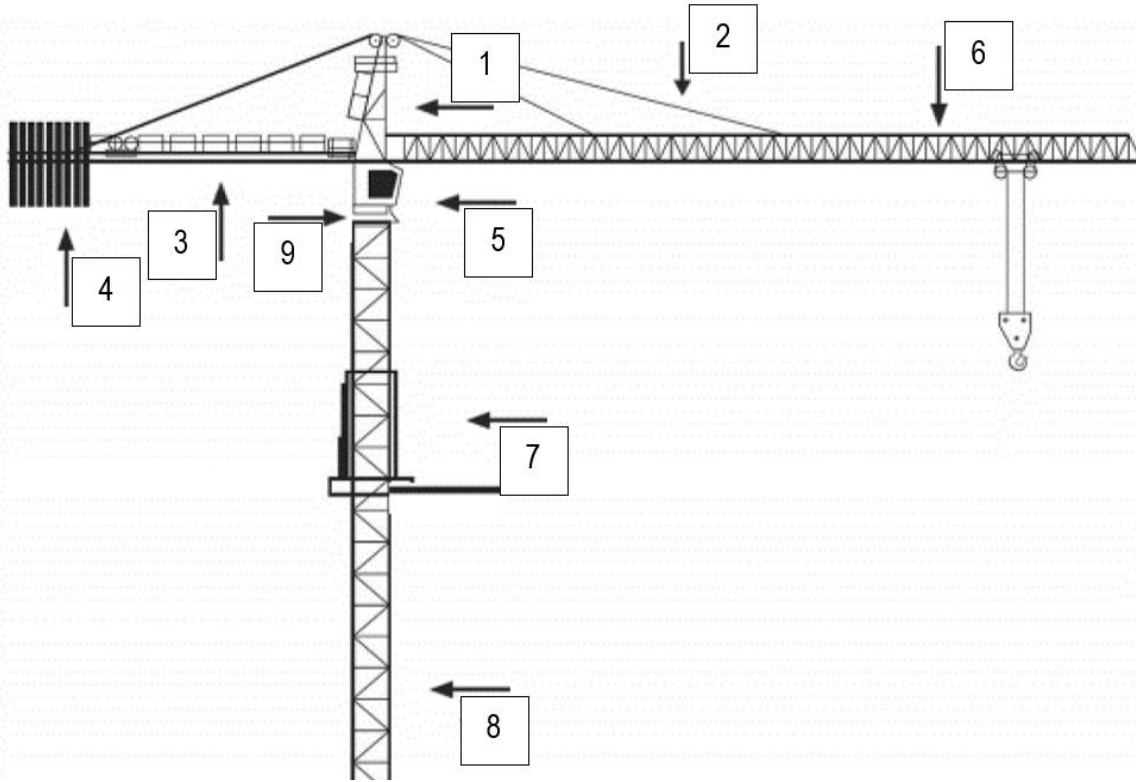
1	
2	
3	
4	
5	
6	
7	
8	
9	

**CPCCLRG3002 Licence to perform rigging intermediate level - ACTIVITY BOOK**

Short Questions	S	NS	Short Questions	S	NS
<p><b>92. How could you establish the amount of free-standing tower sections before you must tie to a building or structure?</b></p> <p>.....</p> <p>.....</p>	<input type="checkbox"/>	<input type="checkbox"/>	<p><b>93. How would you establish the component weights before erecting a tower crane?</b></p> <p>.....</p> <p>.....</p> <p>.....</p>	<input type="checkbox"/>	<input type="checkbox"/>
<p><b>94. Where should the lifting gear be attached to when preparing to lift boom or jib sections?</b></p> <p>.....</p> <p>.....</p> <p>.....</p> <p>.....</p>	<input type="checkbox"/>	<input type="checkbox"/>	<p><b>95. What methods are used to support an internal type tower crane to the inside of a building?</b></p> <p><i>Provide two (2) examples</i></p> <p>.....</p> <p>.....</p> <p>.....</p>	<input type="checkbox"/>	<input type="checkbox"/>
<p><b>96. Why do you need to install or remove tower crane counter weights according to manufacturer's specifications?</b></p> <p>.....</p> <p>.....</p>	<input type="checkbox"/>	<input type="checkbox"/>	<p><b>97. When tensioning tower crane counterweight ropes, how would you stop turnbuckles loosening from vibration?</b></p> <p>.....</p> <p>.....</p>	<input type="checkbox"/>	<input type="checkbox"/>

**CPCCLRG3002 Licence to perform rigging intermediate level - ACTIVITY BOOK**

Short Questions

S

NS

Short Questions

S

NS

The following questions relate to climbing operations for an external climbing tower crane

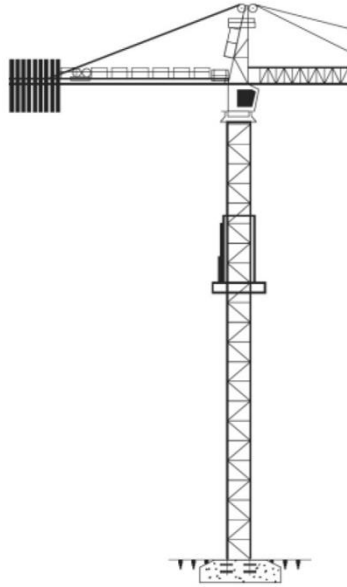

98. How can you establish the maximum wind rating for the external crane climbing activity?



.....  
.....

99. How can you establish information relating to the vertical spacing of ties or collars?



.....  
.....

100. What might happen if the bolts that connect the crane and the climbing frame are disconnected at the same time during the climbing activity?



.....  
.....

101. What person is responsible for communicating with the crane operator from inside the tower?



.....  
.....

**CPCCLRG3002 Licence to perform rigging intermediate level - ACTIVITY BOOK**

Short Questions	S	NS	Short Questions	S	NS
<p>102. What is attached to the tower in order to support the incoming tower section being lifted by the crane?</p> <p>.....</p>	<input type="checkbox"/>	<input type="checkbox"/>			

The following questions relate to climbing operations for an internal climbing tower crane that is setup through a building lift shaft

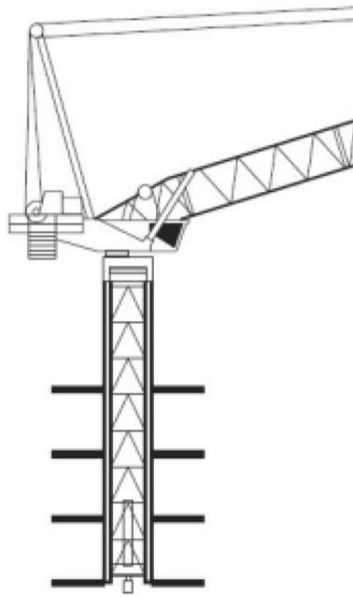

<p>103. When should the tower guides be released to the minimum measurement?</p> <p>.....</p> <p>.....</p>	<input type="checkbox"/>	<input type="checkbox"/>	<p>104. Why do the tower sections need to be clear of obstructions prior to climbing?</p> <p>.....</p> <p>.....</p>	<input type="checkbox"/>	<input type="checkbox"/>
<p>105. Why would the riggers need to adjust the climbing frame guides numerous times throughout the climb?</p> <p>.....</p> <p>.....</p>	<input type="checkbox"/>	<input type="checkbox"/>	<p>106. What procedure is required to equalise the balance on the tower of a luffing type tower crane?</p> <p>(Reach equilibrium)</p> <p>.....</p> <p>.....</p>	<input type="checkbox"/>	<input type="checkbox"/>

CPCCLRG3002 Licence to perform rigging intermediate level - ACTIVITY BOOK					
Short Questions	S	NS	Short Questions	S	NS
<p><b>107. Why would you luff the boom to the minimum radius, when operating a crane with a travelling counterweight?</b></p> <p>.....</p> <p>.....</p>	<input type="checkbox"/>	<input type="checkbox"/>			
<p>The following questions relate to Lattice boom section</p>					
<p><b>108. What information must be obtained to identify the maximum cantilevered boom length supported from the butt section of a mobile lattice boom crane?</b></p> <p><i>Provide two (2) examples</i></p> <p>.....</p> <p>.....</p>	<input type="checkbox"/>	<input type="checkbox"/>	<p><b>109. From which side should the flanged pins be connected when connecting sections of boom?</b></p> <p>.....</p> <p>.....</p>	<input type="checkbox"/>	<input type="checkbox"/>
<p><b>110. Why is it hazardous to remove the lattice boom pins from under and inside the boom?</b></p> <p>.....</p> <p>.....</p>	<input type="checkbox"/>	<input type="checkbox"/>	<p><b>111. Which pins should be removed first, when the boom is cantilevered and the butt section is supported by the bridle during dismantling of a lattice boom crane?</b></p> <p>.....</p> <p>.....</p>	<input type="checkbox"/>	<input type="checkbox"/>
<p><b>112. Before replacing a wire rope on a crane, where would you find information on size, length, lay and construction?</b></p> <p>.....</p> <p>.....</p>	<input type="checkbox"/>	<input type="checkbox"/>	<p><b>113. What could result in the event that a wire rope is not pre-tensioned when being run on a multi-layered hoist drum?</b></p> <p><i>Provide two (2) examples</i></p> <p>.....</p> <p>.....</p> <p>.....</p>	<input type="checkbox"/>	<input type="checkbox"/>

**CPCCLRG3002 Licence to perform rigging intermediate level - ACTIVITY BOOK**

Short Questions	S	NS	Short Questions	S	NS
<p><b>114. How would you establish the inspection or handling requirements for a non-guyed light or crane tower?</b></p> <p>a. The manufacturer specifications            b. Environmental management plan            c. Safety Data Sheets            d. None of the above</p>	<input type="checkbox"/>	<input type="checkbox"/>	<p><b>115. What type of rigging and or associated equipment is required to safely lift a tilt-up concrete panel?</b></p> <p><i>Provide eight (8) examples</i></p> <p>.....</p> <p>.....</p> <p>.....</p> <p>.....</p> <p>.....</p> <p>.....</p> <p>.....</p> <p>.....</p> <p>.....</p>	<input type="checkbox"/>	<input type="checkbox"/>
<p><b>116. What percentage of chemical anchors must be proof tested to working load limit, when used to fix braces?</b></p> <p>.....</p>	<input type="checkbox"/>	<input type="checkbox"/>	<p><b>117. How can you establish the alignment tolerance and minimum number of braces required for each tilt panel?</b></p> <p>.....</p> <p>.....</p> <p>.....</p>	<input type="checkbox"/>	<input type="checkbox"/>

CPCCLRG3002 Licence to perform rigging intermediate level - ACTIVITY BOOK					
Short Questions	S	NS	Short Questions	S	NS
<p>118. When using lifting inserts or bracing inserts, what is the minimum safety factor?</p> <p>.....</p>	<input type="checkbox"/>	<input type="checkbox"/>	<p>119. When do lifting clutches need to be proof tested?</p> <p>.....</p>	<input type="checkbox"/>	<input type="checkbox"/>
<p>120. Why is panel suction or binding hazardous, when lifting a panel from the casting bed?</p> <p>.....</p> <p>.....</p> <p>.....</p>	<input type="checkbox"/>	<input type="checkbox"/>	<p>121. Why would you use rated capacity limiters or load moment indicators when lifting a tilt panel from a casting bed?</p> <p>.....</p> <p>.....</p>	<input type="checkbox"/>	<input type="checkbox"/>
<p>122. How can you establish the rigging configuration required to lift a certain panel?</p> <p>.....</p> <p>.....</p>	<input type="checkbox"/>	<input type="checkbox"/>	<p>123. When can you remove the load from the hook when installing a panel?</p> <p>.....</p> <p>.....</p>	<input type="checkbox"/>	<input type="checkbox"/>
<p>124. What is the minimum allowable width of packers or shims under a panel edge?</p> <p>.....</p> <p>.....</p>	<input type="checkbox"/>	<input type="checkbox"/>	<p>125. What is the maximum allowable height of packers or shims under a panel edge, unless specifically designed?</p> <p>.....</p>	<input type="checkbox"/>	<input type="checkbox"/>

CPCCLRG3002 Licence to perform rigging intermediate level - ACTIVITY BOOK					
Short Questions	S	NS	Short Questions	S	NS
<p><b>126. Who is allowed into an area where tilt panels are being lifted?</b></p> <p>.....</p> <p>.....</p>	<input type="checkbox"/>	<input type="checkbox"/>	<p><b>127. What information regarding adjustable brace working load limit must be accessible?</b></p> <p>.....</p> <p>.....</p>	<input type="checkbox"/>	<input type="checkbox"/>
<p><b>128. What device must be fitted to adjustable brace lock pins?</b></p> <p>.....</p>	<input type="checkbox"/>	<input type="checkbox"/>	<p><b>129. Why is it dangerous to lift a panel that is leaning towards a crane?</b></p> <p>.....</p> <p>.....</p>	<input type="checkbox"/>	<input type="checkbox"/>
<p><b>130. Where are persons allowed to stand, when felling structures by wire rope or chain?</b></p> <p>.....</p>	<input type="checkbox"/>	<input type="checkbox"/>	<p><b>131. What is the minimum allowable horizontal distance between a pulling mechanism and the structure to be felled when using wire rope or chain?</b></p> <p>.....</p> <p>.....</p>	<input type="checkbox"/>	<input type="checkbox"/>
<p><b>132. Why is a pre-cast or pre-stressed beam hazardous when incorrectly slung and turned on its side?</b></p> <p>.....</p> <p>.....</p> <p>.....</p>	<input type="checkbox"/>	<input type="checkbox"/>	<p><b>133. Why would you remove additional or unwanted materials from the work area as soon as possible?</b></p> <p>a. Hazard prevention</p> <p>b. Fill in time</p> <p>c. Safety</p> <p>d. None of the above</p>	<input type="checkbox"/>	<input type="checkbox"/>

**CPCCLRG3002 Licence to perform rigging intermediate level - ACTIVITY BOOK**

Short Questions	S	NS	Short Questions	S	NS
<p><b>134. What action is required if components of structure, plant or equipment are found to be defective?</b></p> <p>a. Tag out b. Isolate c. Record in service or maintenance book d. Report e. None of the above</p>	<input type="checkbox"/>	<input type="checkbox"/>	<p><b>135. How would you correctly store plant, gear and equipment?</b></p> <p>a. As quickly as possible b. According to manufacturer instructions c. According to workplace procedures d. None of the above</p>	<input type="checkbox"/>	<input type="checkbox"/>
<p><b>136. What should you do with hazard control measures such as barriers, signs or safety nets when they are no longer needed?</b></p> <p>a. Remove them from the work area, inspect for defects and store them correctly b. Leave in place c. None of the above</p>	<input type="checkbox"/>	<input type="checkbox"/>			